

# WACONIA CITY COUNCIL REGULAR MEETING AGENDA



**Monday, April 6, 2026  
6:00 PM**

## **VISION STATEMENT**

**A thriving, connected community with deep roots: a great place to live for a lifetime.**

## **MISSION STATEMENT**

**A city that leads, serves, and governs to enhance the quality of life for all community members.**

MAYOR: TIM LITFIN  
COUNCIL MEMBER: NICK GLEASON  
COUNCIL MEMBER: JEFF GRENGS  
COUNCIL MEMBER: JACOB COLEMAN  
COUNCIL MEMBER: DEREK SIDDONS

---

**NOTE: TO ENSURE THAT YOU ARE PRESENT FOR ITEMS OF INTEREST,  
PLEASE BE PRESENT AT 6:00 P.M.**

Those with items on the agenda should reach out to their staff contact. Others who wish to participate in the meeting, please contact the City Administrator at 952-442-3100 or [sfineran@waconiamn.gov](mailto:sfineran@waconiamn.gov) to make certain that you are called upon during the meeting.

**1. CALL MEETING TO ORDER AND ROLL CALL**

**2. PLEDGE OF ALLEGIANCE**

Andrew Jantzen, second-grader, St. Joseph's Catholic School, will lead all in the Pledge of Allegiance.

**3. PROCLAMATIONS**

- 1) Proclamation Declaring April 30, 2026, Therapy Animal Day**  
Mayor to read Proclamation into the record.

**4. ADOPT AGENDA**

**5. PUBLIC HEARING**

**6. OPEN FORUM**

**7. COMMUNITY INTEREST PRESENTATIONS**

## 8. **ADOPT CONSENT AGENDA**

The items listed on the Consent Agenda are considered routine and non-controversial by the Council and will be approved by one motion. There will be no separate discussion of these items unless a Councilmember, City Staff, or Citizen so requests; in which case, the item will be removed from the Consent Agenda and considered at the end of the Regular Agenda.

- 1) **Approve the March 16, 2026, Council Minutes**
- 2) **Approve April 6, 2026 Expenditures**
- 3) **Direct the Preparation of Plans and Specs and Authorize Ad for Bids of the 2026 PMP Mill & Overlay Project CIP No. 132-A**  
Adopt Resolution No. 2026-089 Authorizing the Preparation of Plans and Specifications, and Authorizing Advertisement for Bids for the 2026 PMP Mill & Overlay Project in the Landings Neighborhood.
- 4) **Authorize Execution of JPA for CSAH 10 Regional Trail Connector Project**  
Adopt Resolution No. 2026-090 Authorizing a Joint Powers Agreement with Carver County for the Highway 10 Regional Trail Connection Project.
- 5) **Accept Proposal for Phase 2 Environmental Site Assessment for TH 5 Phase 2 Corridor Improvements**  
Adopt Resolution No. 2026-091 Authorizing the Proposal for Phase 2 Environmental Site Assessment in support of the Trunk Highway 5 Phase 2 Corridor Improvements
- 6) **Accept Proposal for Geotechnical Services for the Downtown Phase 4 Reconstruction project**  
Adopt Resolution No. 2026-092 Accepting the Proposal for Special Inspection and Testing Services for the Downtown Phase 4 Reconstruction project.
- 7) **2026 Capital Equipment**  
Adopt Resolution No. 2026-093 Authorizing Acquisition of Capital Equipment
- 8) **Lodging Tax Fund Request - Waconia Convention & Visitors Bureau (CVB)**  
Motion to Approve Request for Lodging Tax Reimbursement from the Waconia CVB for Expenditures Incurred January through March 2026
- 9) **Cash Donations for Fire Safety and Prevention Efforts and Approving Pass Thru to the National Fire Safety Council**  
Adopt Resolution No. 2026-094 Accepting Cash Donations Fire Safety and Prevention Efforts
- 10) **Donation and Approve Pass Thru Recommendation - Waconia Fire Relief Association**  
Adopt Resolution No. 2026-095 Accepting Donation and Approving Pass Through Recommendation from Waconia Fire Relief Association
- 11) **Sale or Disposal of Surplus Equipment**  
Adopt Resolution No. 2026-096 Approving Surplus Equipment and Sale
- 12) **Waconia Works Loan, 125 1st Street West, Bakery Off Main**  
Adopt Resolution No. 2026-097 Approving Waconia Works Loan for Bakery Off

Main Relocating at 125 1st Street West

**9. COUNCIL BUSINESS**

**1) Special Event Permit - Farmers Market**

Adopt Resolution No. 2026-098 approving the Special Event Permit for the Waconia Farmers Market

**2) Order Feasibility Report and Assessment Benefit Evaluation for 5th Street Reconstruction**

Adopt Resolution No. 2026-099 Ordering a Feasibility Report and Assessment Benefit Evaluation for 5th Street Reconstruction

**3) Authorize Feasibility Study for a Public Services Office Expansion**

Adopt Resolution 2026-100 Authorizing Feasibility Study for Public Services Office Expansion project

**4) Cold Storage Building Design - Professional Services Agreement Addendum**

Adopt Resolution No. 2026-101 Authorizing Approval of Addendum to WTP 4 Design Professional Services Agreement with SEH, Inc.

**5) Award CSAH 10 Regional Trail Connector Project**

Adopt Resolution No. 2026-102 Authorizing Award of Contract for CSAH 10 Regional Trail Connection project

**6) Provide for the Issuance and Sale of General Obligation Bonds, Series 2026A and 2026B and Call a Public Hearing for Issuance**

Adopt Resolution No. 2026-103 Providing for the Issuance and Sale of \$9,520,000 General Obligation Bonds, Series 2026A

Adopt Resolution No. 2026-104 Providing for the Issuance and Sale of \$3,265,000 General Obligation Temporary Street Reconstruction Bonds, Series 2026B

Adopt Resolution No. 2026-105 Calling a Public Hearing on the Proposal to Adopt a Street Reconstruction Plan and the Intent to Issue General Obligation Street Reconstruction Bonds

**10. ITEMS REMOVED FROM CONSENT AGENDA**

**11. STAFF REPORTS**

**1) Law Enforcement Update - Sgt. Jon Howard**

**12. BOARD REPORTS**

**1) Staff Reports**

**2) Councilmember Siddons**

**3) Councilmember Coleman**

**4) Councilmember Gleason**

**5) Councilmember Grengs**

**6) Mayor Litfin**

**13. ANNOUNCEMENTS**

**14. ADJOURN REGULAR MEETING**

**OFFICE OF THE CITY ADMINISTRATOR  
Shane Fineran**

**WORK SESSION: COMMUNITY NEEDS ASSESSMENT FINAL REPORT, WATER  
TREATMENT PLAN #4 DESIGN UPDATE**

UPCOMING CALENDAR OF EVENTS/MEETINGS:



**REQUEST FOR CITY COUNCIL ACTION**

<b>Meeting Date:</b> April 6, 2026	
<b>Item Name:</b> 3.1. Proclamation Declaring April 30, 2026, Therapy Animal Day	
<b>Originating Dept:</b> Administration	
<b>Presented By:</b>	
<b>Previous Council Action:</b>	
<b>Item Type:</b>	Discussion
<b>RECOMMENDATIONS/COUNCIL ACTION/MOTION REQUESTED:</b> Mayor to read Proclamation into the record.	
<b>EXPLANATION OF AGENDA ITEM:</b>	
<b>ATTACHMENTS:</b> 1. Proclamation Therapy Animal Day	
<b>FINANCIAL IMPLICATIONS:</b>	<b>ADVISORY BOARD RECOMMENDATIONS:</b>
Funding Sources & Uses:	Planning Commission:
Budget Information:	Park Board:
_____ Budgeted	Personnel Committee:
_____ Non-Budgeted	Other:
_____ Amendment Required	



## PROCLAMATION

DECLARING APRIL 30, 2026, THERAPY ANIMAL DAY

IN THE CITY OF WACONIA

**WHEREAS:** April 30<sup>th</sup> is recognized as National Therapy Animal Day in honor of the thousands of therapy animals serving in communities across the United States; and

**WHEREAS:** Therapy animals are more than just pets, and they play a vital role in supporting a person's independence, health, and well-being; and

**WHEREAS:** Therapy animal teams make millions of visits per year in settings such as hospitals, nursing homes, schools, and hospices to foster strong human-animal bonds and pair animals with veterans, seniors, patients, students, those with disabilities, and those seeking end-of-life care; and

**WHEREAS:** These exceptional therapy animals who partner with their human companions bring comfort and healing to those in need; and

**WHEREAS:** People in Waconia are encouraged to celebrate therapy animals and their human handlers, and recognize the impeccable service they provide in our communities to foster accessibility and wellness for all.

**NOW, THEREFORE, I, Tim Litfin, Mayor Waconia, do hereby proclaim Thursday, April 30, 2026, as Therapy Animal Day in the City of Waconia.**

---

Mayor, Tim Litfin

---

Shane Fineran, City Administrator



**REQUEST FOR CITY COUNCIL ACTION**

<b>Meeting Date:</b> April 6, 2026	
<b>Item Name:</b> 8.1. Approve the March 16, 2026, Council Minutes	
<b>Originating Dept:</b> Administration	
<b>Presented By:</b> Sue Schwalbe	
<b>Previous Council Action:</b> None	
<b>Item Type:</b>	Consent
<b>RECOMMENDATIONS/COUNCIL ACTION/MOTION REQUESTED:</b> Approve the March 16, 2026 Council Minutes	
<b>EXPLANATION OF AGENDA ITEM:</b> Approve the March 16, 2026, Council Minutes.	
<b>ATTACHMENTS:</b> 1. March 16, 2026, Council Minutes	
<b>FINANCIAL IMPLICATIONS:</b>	<b>ADVISORY BOARD RECOMMENDATIONS:</b>
Funding Sources & Uses:	Planning Commission:
Budget Information:	Park Board:
_____ Budgeted	Personnel Committee:
_____ Non-Budgeted	Other:
_____ Amendment Required	

**CITY OF WACONIA  
MARCH 16, 2026**

**1. CALL MEETING TO ORDER AND ROLL CALL**

Mayor Litfin called the March 16, 2026, Waconia City Council Meeting to order at 6:00 p.m. with Council Member Coleman absent.

**2. PLEDGE OF ALLEGIANCE**

Trinty Lutheran School 7th grader, Vyctor Traver led all in the Pledge of Allegiance.

**3. PROCLAMATIONS**

None

**4. ADOPT AGENDA**

Motion to adopt the consent agenda as published was made by Council Member Grengs, seconded by Council Member Siddons.

**MOTION CARRIED.**

**5. PUBLIC HEARING**

**1) Fee Schedule Ordinance Amendment — Waconia City Code Chapter 1100**

Nicole Meyer, Finance Director, stated that it is necessary under Minnesota State Law that the City holds a public hearing before a zoning ordinance is amended and that Chapter 1100 of the City Code contains zoning and land use fees charged by the City. The City holds a public hearing for the entire fee schedule each year to avoid inadvertently violating this requirement for land use/zoning fee changes.

Motion to open the Public Hearing was made by Council Member Gleason, seconded by Council Member Siddons.

**MOTION CARRIED.**

No verbal or written comments were received.

Motion to close the Public Hearing was made by Council Member Gleason, seconded by Council Member Grengs.

**MOTION CARRIED.**

Motion to adopt Ordinance No. 792 amending Chapter 1100 of the Waconia City Code related to Permits, Licenses, and Fees was made by Council Member Siddons, seconded by Council Member Gleason.

**MOTION CARRIED.**

Motion to adopt Resolution No. 2026-076 Summary Publication of Ordinance No. 792 was made by Council Member Gleason, seconded by Council Member Grengs.

**MOTION CARRIED.**

**6. OPEN FORUM**

None.

**7. COMMUNITY INTEREST PRESENTATIONS**

None.

**8. ADOPT CONSENT AGENDA**

- 1) **Approve March 2, 2026, City Council Minutes**
- 2) **Approve March 16, 2026, Expenditures**
- 3) **Safari Island Community Center Expenditures from Sports Facilities Companies Incurred February 2026**
- 4) **Ice Arena Expenditures from Sports Facilities Companies Incurred February 2026**
- 5) **Innovent Unit Replacement — Waconia Ice Arena Facility**
- 6) **CSAH 10 & Waconia Parkway North Improvements Pay Request #6**
- 7) **2025 Pond Cleaning Pay Request No.1 to Schneider Excavating and Grading, Inc.**
- 8) **2025 Bent Creek Culvert Lining Project Change Order #1**
- 9) **2026 Dock Slip Lease for the Fire Department Boat**
- 10) **Firefighters' Leave of Absence**
- 11) **Carver County Multi-Hazard Mitigation Plan**
- 12) **Interfund Loan from General Fund to PIR Capital Project Fund - Year End 2025**
- 13) **Agreement for Can Trailer Location - Troop 327**
- 14) **Authorize Execution of Contract for Compost Collection Services**
- 15) **Approval of Laserfische Migration to Cloud Upgrade**
- 16) **Special Event Permit - Promise Church**
- 17) **Off-Site Gambling- Waconia Lions Club**
- 18) **Off-Site Gambling - Minnesota USA Wrestling Inc**

Motion to adopt the Consent Agenda as published was made by Council Member Siddons, seconded by Council Member Grengs.

**MOTION CARRIED.**

## 9. COUNCIL BUSINESS

### 1) Franchise Agreement - Minnesota Valley Electric

Nicole Meyer stated that Staff have been working to finalize language with the Minnesota Valley Electric Cooperative (MVEC) on an electric franchise agreement. The City currently has a franchise agreement with MVEC; however, a formal agreement must be approved by Ordinance of the Council. This Ordinance grants MVEC a non-exclusive franchise to provide electric energy and establishes the terms of the agreement. The updated language clearly outlines how the City and MVEC will coordinate construction activities within the City right-of-way.

Motion to approve Ordinance 790 made by Council Member Gleason, seconded by Council Member Grengs.

**MOTION CARRIED.**

Motion to adopt Resolution No. 2026-035 made by Council Member Grengs, seconded by Council Member Siddons.

**MOTION CARRIED.**

### 2) Special Event Permit - 2026 Earth Day Event

Shane Fineran, City Administrator, stated that the City received a Special Event Permit from Podium Sports Marketing for a special event permit for a 2026 Earth Day event. This event is scheduled for April 26, 2026, and will be held at City Square Park. The Earth Day Event is anticipated to last two hours and approximately 75 students and their supervisors will pick up litter along a designated route including sidewalks, boulevards, curbs, and within City Square Park. Students will be provided with plastic bags, gloves, and vests for safety. The applicant is requesting the Council approve this as a City Supported Event under the Special Event Permit policy, that the permit fees as well as the rental fees be waived, and an additional in-kind donation for portable toilets based on weather conditions.

Motion to adopt Resolution No. 2026-088 approving a Special Event Permit and Temporary Noise Permit for the Waconia +30 Earth Day Event was made by Council Member Siddons, seconded by Council Member Grengs.

**MOTION CARRIED.**

### 3) Annexation Petition – Wolter and Klingelutz

Lane Braaten, Community Development Director, stated that his item is a continuation from the March 2, 2026, Council meeting. At that meeting, Council directed Staff to work with the City Attorney to explore allowing annexation contingent upon an agreement for utilities to be provided at a later date. The City Attorney recommended denial of the annexation, as outlined in the Council packet. Staff also received an email from the applicant's representative requesting that the item be tabled for 30 days to allow time to address concerns raised by the City Attorney and Staff.

All Council Members were in agreement to table this item for 30 days.

Motion to table the Annexation Petition Request submitted by Eugene E & Carol Wolter and Klingelhutz Farms LLC to the April 20, 2026, regular City Council meeting was made by Council Member Siddons, seconded by Council Member Grengs.

**MOTION CARRIED.**

## **10. ITEMS REMOVED FROM CONSENT AGENDA**

None.

## **11. BOARD REPORTS**

### **1) Staff Reports — Sgt. Jon Howard**

Sgt. Jon Howard not available for Staff Report.

### **2) Staff Reports — Land Use Summary 2025 Lane Braaten, Community Development Director**

Lane Braaten provided the Council with the 2025 Land Use Summary. The Planning Commission is scheduled to review this information on April 9, after which the full packet will be posted on the City's Website. Mr. Braaten reported that a total of 2,491 permits were issued in 2025, an increase from 853 permits in 2024. However, overall permit activity has remained relatively consistent since 2021. The total construction value rose significantly from \$61.8 million in 2024 to \$134.5 million in 2025, driven in part by projects such as Tractor Supply Store, Goodwill, The Wilford, and Transport Security. He also noted a substantial increase in the number of e-permits issued in 2025. Residential development included 119 new single-family homes and 103 multi-family units. In the commercial sector, 157 permits were issued in 2025, up from 104 in 2024 and 94 in both 2022 and 2023. As of the end of 2025, the City had 329 single-family lots, 44 townhome lots, 28.1 acres of commercial land, and one industrial lot totaling 2.37 acres available for development.

In summary, 2025 saw 2,491 total building permits issued, 222 new housing units constructed, 30.47 acres of commercial and industrial land available for development, an estimated population of 15,850, 158 commercial and industrial permits issued, and 373 buildable lots available.

Council thanked the Community Development Department and the Building/Inspections Department for a job well done.

### **3) Councilmember Siddons**

Nothing to report.

**4) Councilmember Coleman**

Absent.

**5) Councilmember Gleason**

Nothing to report.

**6) Councilmember Grengs**

Nothing to report

**7) Mayor Litfin**

**Mayor's Report – March 16, 2026**

Thank you to Zac Coauette, Manager of Westview Acres, along with residents Bob and Bob, for their time as we taped a *Mayor's Minute* at Westview Acres.

Thank you as well to Angie Cruisen from Gather and Grow for hosting another *Mayor's Minute*.

Met with Carver County Commissioner Matt Udermann to discuss shared interests between the County and the City.

Presented to the Waconia Middle School Student Council, which is 39 members strong. Thank you to Ms. Cindy Schook for arranging the presentation. Our future is in good hands, and that was clearly on display through the students' strong interest and thoughtful questions.

Congratulations to the new Tractor Supply Store on their grand opening, and thank you to Manager Todd Christopherson for participating in a *Mayor's Minute*.

On March 4, the Waconia +30 group met, with 12 participants representing public and private fitness centers, Podium Sports, the Chamber of Commerce, Waconia Living, and Gather and Grow. Each organization shared updates on how they are helping energize the community through the +30 initiative.

Also on March 4, I was invited to lead the Senior Center in a new card game, which was a lot of fun. Thank you to Kathy Sissler for her great work. On March 26, the group will honor Shirley Heinen, who recently passed away.

On March 6, I hosted the Carver County Mayors for our bi-monthly meeting at Egg Cetera, with seven mayors in attendance.

On March 12, the City, along with Bolton & Menk, hosted an open house for both the

2027 Downtown Reconstruction Project and the Highway 5 Reconstruction Project. The event was well attended, with many great questions. Thank you to all who took the time to participate.

On March 14, I attended The Paws Inn open house. It is a business well worth visiting, offering a wide range of services for our pets.

**12. ANNOUNCEMENTS**

Shane Fineran stated he is hosting open office hours on Thursday, March 19th, from 5:00 to 6:15 p.m.in the Oak Conference Room.

**13. ADJOURN REGULAR MEETING**

Motion made by Council Member Grengs, seconded by Council Member Siddons to adjourn the March 16, 2026, Waconia City Council meeting at 6:30 p.m.

\_\_\_\_\_  
Tim Litfin, Mayor

ATTEST: \_\_\_\_\_  
Sue Schwalbe, Administrative Specialist



**REQUEST FOR CITY COUNCIL ACTION**

<b>Meeting Date:</b> April 6, 2026	
<b>Item Name:</b> 8.2. Approve April 6, 2026 Expenditures	
<b>Originating Dept:</b> Finance	
<b>Presented By:</b> Nicole Meyer	
<b>Previous Council Action:</b> None	
<b>Item Type:</b>	Consent
<b>RECOMMENDATIONS/COUNCIL ACTION/MOTION REQUESTED:</b> Approve April 6, 2026 Expenditures	
<b>EXPLANATION OF AGENDA ITEM:</b> Attached are the claim and disbursement registers for the City of Waconia as of April 6, 2026. Payments are made to vendors via check, electronic payment, and through the City's purchasing card program.	
<b>ATTACHMENTS:</b> None	
<b>FINANCIAL IMPLICATIONS:</b>	<b>ADVISORY BOARD RECOMMENDATIONS:</b>
Funding Sources & Uses:	Planning Commission:
Budget Information:	Park Board:
_____ Budgeted	Personnel Committee:
_____ Non-Budgeted	Other:
_____ Amendment Required	



**REQUEST FOR CITY COUNCIL ACTION**

<b>Meeting Date:</b>	April 6, 2026
<b>Item Name:</b>	8.3. Direct the Preparation of Plans and Specs and Authorize Ad for Bids of the 2026 PMP Mill & Overlay Project CIP No. 132-A
<b>Originating Dept:</b>	Public Services
<b>Presented By:</b>	Jon Haukaas
<b>Previous Council Action:</b>	Resolution No. 2025-264 Accepting the 2025 Pavement Management Plan Update
<b>Item Type:</b>	Consent
<p><b>RECOMMENDATIONS/COUNCIL ACTION/MOTION REQUESTED:</b> Adopt Resolution No. 2026-089 Authorizing the Preparation of Plans and Specifications, and Authorizing Advertisement for Bids for the 2026 PMP Mill &amp; Overlay Project in the Landings Neighborhood.</p> <p><b>EXPLANATION OF AGENDA ITEM:</b></p> <p>The City Council directed staff to develop a long-term Pavement Management Plan (PMP) to guide the future investment in improving our transportation infrastructure throughout the city. This PMP has been used to create a recommendation of streets that would benefit from a mill and overlay pavement rehabilitation. Projects are typically grouped into neighborhood areas for economy and to minimize disruptions. Geotechnical cores of the pavement and sub-grade are collected to support this recommendation and verify final project scope. Utilizing the data collected from the pavement condition rating evaluation as well as knowledge of the maintenance staff, streets in the Landings Neighborhood in the northwest portion of the city are recommended for mill and overlay in 2026.</p> <p>It is recommended to proceed with the following steps for the proposed M&amp;O project:</p> <ul style="list-style-type: none"> <li>• Authorize the completion of the final design and the preparation of plans and specifications.</li> <li>• Authorize advertising for bids in order to identify the contractor and the low bid amount.</li> </ul> <p>If the above are authorized, the tentative project schedule would then be as follows:</p> <ul style="list-style-type: none"> <li>• Final Plans &amp; Specs Complete – April 17th</li> <li>• Advertise for Bidding – April 16th to May 7th</li> <li>• Bid Opening – May 12th</li> <li>• Award Contract – May 18th</li> <li>• Start Construction – Mid June</li> </ul> <p>Staff recommends approval to advance the project for work to be completed later this year.</p>	

**ATTACHMENTS:**

1. Resolution No.2026-089 Mill & Overlay Project 2026
2. Project Location Map - The Landings
3. 2026-03-31 2026 M&O Auth Memo

<b>FINANCIAL IMPLICATIONS:</b>	<b>ADVISORY BOARD RECOMMENDATIONS:</b>
Funding Sources & Uses:	Planning Commission:
Budget Information:	Park Board:
<input checked="" type="checkbox"/> Budgeted	Personnel Committee:
<input type="checkbox"/> Non-Budgeted	Other:
<input type="checkbox"/> Amendment Required	

**CITY OF WACONIA  
 RESOLUTION NO. 2026-089  
 RESOLUTION AUTHORIZING PREPARATION OF PLANS AND SPECIFICATIONS  
 AND AUTHORIZING ADVERTISEMENT FOR BIDS OF THE  
 202 PAVEMENT MANAGEMENT PLAN MILL & OVERLAY PROJECT CIP 132-A**

**WHEREAS**, one of the City’s Priorities is managing, maintaining, and improving our current and future physical infrastructure assets; and

**WHEREAS**, the 2026 Capital Improvement Plan included funding to perform road resurfacing; and

**WHEREAS**, the City has developed a Pavement Management Plan to guide its effort for rehabilitation of pavement surfaces throughout the community and; and

**WHEREAS**, in 2024 all city streets were surveyed for a new road condition rating to assist in the prioritization of pavement projects; and

**WHEREAS**, the Pavement Management Plan and most recent Road Condition Rating have identified roadways in the Landings neighborhood listed below as being the best candidates for a mill and overlay pavement rehabilitation project.

<b>The Landings Neighborhood</b>		
Street:	From:	To:
Beachcomber Blvd	Sandbar Cir	Willowbrooke Ln
Beachcomber Blvd	Willowbrooke Ln	Cul-de-sac
Willowbrooke Ln	Beachcomber Blvd	Waconia Pkwy N
Braunwarth Cir	Sandbar Cir	Cul-de-sac
Sandbar Cir	Sandbar Cir	Cul-de-sac
Sandbar Cir	Sandbar Cir	Sandbar Cir
Sandbar Cir	Seashell Ln	Sandbar Cir
Sandbar Cir	Beachcomber Blvd	Seashell Ln
Sandbar Cir	Braunwarth Cir	Beachcomber Blvd
Sandbar Cir	Seashell Ln	Braunwarth Cir
Sandbar Cir	Sandbar Cir	Seashell Ln
Sandbar Cir	Sandbar Cir	Waconia Pkwy N
Seashell Ln	Sandbar Cir	Sandbar Cir
Whitecap Ln	Beachcomber Blvd	Beachcomber Blvd

**NOW, THEREFORE, BE IT RESOLVED** That the City Council of the City of Waconia hereby directs staff to prepare plans and specifications for the 2026 PMP Mill & Overlay Project and authorizes advertisement for bids for the project.

Adopted by the City Council of the City of Waconia this 6th day of April 2026.

\_\_\_\_\_

Tim Litfin, Mayor

Attest: \_\_\_\_\_  
Jackie Schulze, Assistant City Administrator

# 2026 PMP Mill & Overlay Project Area

## The Landings Neighborhood





## MEMORANDUM

**Date:** March 31, 2026  
**To:** Jon Haukaas, Director of Public Services  
**From:** Colton Lee, Bolton & Menk  
**CC:** Jake Saulsbury, Bolton & Menk  
**Subject:** 2026 Mill & Overlay Project

---

Honorable Mayor and City Council Members:

The purpose of this memo is to request authorization to advertise for bids for the above referenced project.

The project contains the following components:

- Mill & Overlay of all streets in the Waconia Landing Neighborhood.
- Installation of storm sewer sump structures.
- Repair draintile and the addition of cleanouts.
- Spot repair of damaged curb and gutter sections.

Project Schedule:

- Final Plans & Specs Complete – April 17<sup>th</sup>
- Advertise for Bidding – April 16<sup>th</sup> to May 7<sup>th</sup>
- Bid Opening – May 12<sup>th</sup>
- Award Contract – May 18<sup>th</sup>
- Start Construction – Mid June

The project schedule is detailed above, with a bid opening date of May 18. A plan sheet showing the project area is attached. The final plans are currently being updated to incorporate utility items as directed by City staff and will be forwarded once this work is complete. Approval is being requested at this time to allow the project to be bid as soon as the plans are finalized.

Please let me know if you have any questions or if you require any additional information.



LAKE WACONIA

CSAH 10

BRAUNWARTH CIR

SANDBAR CIR

SEASHELL LN

SANDBAR CIR

BEACHCOMBER BLVD

WHITECAP LN

BEACHCOMBER BLVD

WACONIA PARKWAY NORTH

LAKERIDGE WAY

COURTLAND W

COURTLAND E

WILLOWBROOK LN

WOODLAWN CIR

SUGARBUSH LN

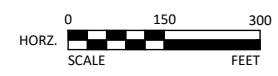

I HEREBY CERTIFY THAT THIS PLAN, SPECIFICATION, OR REPORT WAS PREPARED BY ME OR UNDER MY DIRECT SUPERVISION AND THAT I AM A DULY LICENSED PROFESSIONAL ENGINEER UNDER THE LAWS OF THE STATE OF MINNESOTA.

COLTON A. LEE  
LIC. NO. 61620 DATE MM/DD/YYYY



2638 SHADOW LANE, SUITE 200  
CHASKA, MN 55318  
Phone: (952) 448-8838  
Email: Chaska@bolton-menk.com  
www.bolton-menk.com



DESIGNED	NO.	ISSUED FOR	DATE
DO			
DRAWN			
MJJI			
CHECKED			
CAL			
CLIENT PROJ. NO.	26X142732000		

CITY OF WACONIA, MINNESOTA  
2026 STREET IMPROVEMENTS  
GENERAL PLAN LAYOUT

SHEET 3 OF 12

© Bolton & Menk, Inc. 2026. All Rights Reserved. WACONIA\_26X142732000\_CAD\_2026.dwg 3/29/2026 3:31:15 PM Plotted by: jahl labeled



**REQUEST FOR CITY COUNCIL ACTION**

<b>Meeting Date:</b> April 6, 2026	
<b>Item Name:</b> 8.4. Authorize Execution of JPA for CSAH 10 Regional Trail Connector Project	
<b>Originating Dept:</b> Public Services	
<b>Presented By:</b> Jon Haukaas	
<b>Previous Council Action:</b> Resolution No. 2026-022 Authorizing the Preparation of Plans and Specifications and Authorizing Advertisement for Bids of the CSAH 10 Connector Trail project	
<b>Item Type:</b>	Consent
<p><b>RECOMMENDATIONS/COUNCIL ACTION/MOTION REQUESTED:</b> Adopt Resolution No. 2026-090 Authorizing a Joint Powers Agreement with Carver County for the Highway 10 Regional Trail Connection Project.</p> <p><b>EXPLANATION OF AGENDA ITEM:</b></p> <p>A longstanding goal of the City has been to connect the City’s trail system to the Sterling Hill neighborhood while also providing a safer alternative to walking and biking along the shoulder of CSAH 10. A trail along CSAH 10, north of Sterling Road, was originally included in the recent CSAH 10 / Waconia Parkway North roundabout project but was later removed due to overall budget constraints.</p> <p>Staff worked with Carver County to secure commitments for a portion of the construction costs and to develop a Joint Powers Agreement (JPA) outlining the roles and responsibilities of each party related to this project. This commitment is currently verbal and must be formally approved by both the City Council and County Board. The County Board is scheduled to approve the JPA at its April 7 meeting.</p> <p>The Minnesota Department of Natural Resources (DNR) Local Trails Connections Program grant funds awarded in 2024 will expire on June 30, 2026. Accordingly, the goal is to complete the trail project from Sterling Road to Waconia Parkway North this upcoming spring.</p> <p>Staff recommends approval to execute the attached Joint Powers Agreement allowing for the City and County to share in the costs of the project and complete this important trail connection segment.</p> <p><b>ATTACHMENTS:</b></p> <ol style="list-style-type: none"> <li>1. Resolution No. 2026-090 JPA for Highway 10 Regional Trail Connection</li> <li>2. JPA Highway 10 Regional Trail Project - Hills Lake Area</li> </ol>	
<b>FINANCIAL IMPLICATIONS:</b>	<b>ADVISORY BOARD RECOMMENDATIONS:</b>
Funding Sources & Uses:	Planning Commission:
Budget Information:	Park Board:
<input checked="" type="checkbox"/> Budgeted	Personnel Committee:
_____ Non-Budgeted	

<u>          </u> Amendment Required	Other: <hr/>
--------------------------------------	-----------------

**CITY OF WACONIA  
RESOLUTION NO. 2026-090**

**RESOLUTION AUTHORIZING EXECUTION OF A JOINT POWERS AGREEMENT WITH CARVER  
COUNTY FOR  
HIGHWAY 10 REGIONAL TRAIL CONNECTION PROJECT**

**WHEREAS**, one of the City’s Priorities is to “manage, maintain, and improve our current and future physical assets”; and

**WHEREAS**, a goal of the City has long been to connect the City’s trail system from Waconia Parkway North to the Sterling Hill neighborhood to provide a safer alternative to walking/biking on the shoulder of CSAH 10; and

**WHEREAS**, the project was originally designed and later removed from the Waconia Parkway North and CSAH 10 roundabout project due to funding issues; and

**WHEREAS**, the City has received a new funding commitment from Carver County for a portion of the construction costs and still has access to the grant from the Minnesota Department of Natural Resources (DNR) Local Trails Connections Program; and

**WHEREAS**, City and County Officials are prepared to execute a Joint Powers Agreement for Construction of the Highway 10 Regional Trail Connection as programmed in each entity’s Capital Improvement Plan.

**NOW, THEREFORE, BE IT RESOLVED** That the City Council of the City of Waconia hereby authorizes the Mayor and City Administrator to execute Joint Powers Agreement with Carver County for Highway 10 Regional Trail Connection project.

Adopted by the City Council of the City of Waconia this 6th day of April 2026.

\_\_\_\_\_  
Tim Litfin, Mayor

Attest: \_\_\_\_\_  
Jackie Schulze, Assistant City Administrator

**JOINT POWERS AGREEMENT FOR CONSTRUCTION  
OF TRAIL ALONG COUNTY STATE AID HIGHWAY 10**

**THIS JOINT POWERS AGREEMENT FOR CONSTRUCTION OF A SEGMENT OF THE FUTURE REGIONAL LINKING TRAIL ALONG COUNTY STATE AID HIGHWAY 10** ("Agreement") is entered into by and between the City of Waconia ("City"), and the County of Carver ("County"), (each individually sometimes hereinafter called a "Party" and both sometimes collectively called the "Parties"). Each Party is a local governmental unit and political subdivision of the State of Minnesota.

**WITNESSETH:**

**WHEREAS**, each Party has statutory authority to establish, locate, construct, improve, and maintain public roads within their respective jurisdictions; and

**WHEREAS**, The County State Aid Highway 10 ("CSAH 10") is to be a duly dedicated public street, located within the corporate limits of the City; and

**WHEREAS**, the Parties desire to undertake a joint project and cooperate with one another to provide for the construction of a segment of the future regional linking trail along CSAH 10 located within the City, including the construction of grading, aggregate base, bituminous trail pavement surfacing, storm sewer, and other incidentals ("**Project**"), and to share the costs of the Project as herein provided; and

**WHEREAS**, the statutory authority of the Parties to enter into this Agreement is provided by Minnesota Statutes, Section 471.59.

**NOW, THEREFORE**, in consideration of the mutual promises and covenants of each Party to the other Party and for other good and valuable consideration, the receipt of which hereby is acknowledged, the Parties covenant and agree as follows:

**ARTICLE I**  
**THE AGREEMENT**

**Section 1.01. Purpose.** The purpose of this Agreement is to define the rights and obligations of each Party with respect to the Project and the sharing of the costs of the Project.

**Section 1.02. Cooperation.** The Parties shall cooperate with one another and use their best efforts to ensure the most expeditious implementation of the various provisions of this Agreement. The Parties shall exercise good faith to undertake the resolution of disputes that arise between the Parties regarding this Agreement, if any, in an equitable and timely manner. The Project shall be open to inspection of duly authorized representatives of the Parties at any time during normal business hours and as often as reasonably deemed necessary.

**Section 1.03. Relationship To Other Contracts.** The Parties acknowledge that the Contract Documents will be entered into by the City with respect to the Project, and that Change Orders or other documents may be entered into by the City on behalf of the Parties with respect to the Project as provided herein. This Agreement shall be construed so as to give the fullest effect to its provisions, consistent with the provisions of the other contracts and documents referred to above.

**Section 1.04. Effective Date.** This Agreement shall be effective on the date signed by the last Party (“Effective Date”).

**Section 1.05. Term.** The term of this Agreement shall commence on the Effective Date and terminate on the date the Project is completed, accepted by the Parties and all amounts owed by one Party to the other have been paid in full.

**Section 1.06. Recitals.** The above recitals are true and correct as of the date hereof and shall be fully made a part of this Agreement, as if set forth in their entirety herein.

**Section 1.07 Enabling Authority.** Minnesota Statutes, Section 471.59, allows governmental units by agreement entered into through action of their governing bodies to jointly exercise any power common to the contracting parties, and also allows one of the participating governmental units to exercise such powers on behalf of the other participating governmental unit.

## **ARTICLE II** **DEFINITIONS**

**Section 2.01. Definitions.** In this Agreement the following terms shall have the following meanings unless the context requires otherwise:

- (a) **Agreement:** this Agreement, as it may be amended, supplemented, or restated from time to time.
- (b) **Change Order:** a work change order to the Contractor approved in writing, which may be electronic, and signed by the City Representative authorizing a change in the work included within the Contract Documents and/or an adjustment in the price and/or an adjustment in the construction schedule, issued after execution of the contract for the construction of the Project. Each work change order shall be subject to County approval in accordance with Section 3.04.
- (c) **City:** the City of Waconia.
- (d) **City Representative:** Shane Fineran, City Administrator or their authorized designee.
- (e) **City Costs:** the direct and indirect costs of City employees performing services on behalf of the Project, and other incidentals.

- (f) **Construction Phase Professional Services Costs:** the fees and costs for all professional services performed in Construction Phase Activities for the Project.
- (g) **Contract Documents:** drawings; Engineers Estimate; specifications; general and special conditions; addenda, if any; insurance coverages; Change Orders; and the construction contract for the Project; approved by the Parties, or the authorized Parties representatives.
- (h) **Contractor:** the person or entity that is awarded the contract for the construction of the Project.
- (i) **County:** Carver County.
- (j) **County Costs:** the direct and indirect costs of County employees performing services on behalf of the Project, and other incidentals.
- (j) **County Representative:** Lyndon Robjent, P.E., Carver County Engineer or their authorized designee.
- (k) **Design Phase Professional Services Costs:** the fees and costs for all professional services performed in Design Phase Activities for the Project.
- (l) **Engineers Estimate:** the professional engineer's opinion of probable cost prior to the bidding of the Project, which encompasses all projected costs tabulated for each Party.
- (m) **Project:** grading, aggregate base, bituminous trail, storm sewer, and other incidentals.
- (n) **Project Costs:** all costs for and associated with the construction of the Project, excluding Design Phase Professional Services Costs, Construction Phase Professional Services Costs, and City/County Costs.
- (o) **Project Location:** Adjacent and within the rights-of-way of CSAH 10 from Sterling Road to approximately 300 feet south of Waconia Parkway North as generally depicted in Exhibit A.
- (p) **Uncontrollable Circumstances:** the occurrence or non-occurrence of acts or events beyond the reasonable control of the Party relying thereon, and not the result of willful or negligent action or inaction of the Party claiming the event as an Uncontrollable Circumstance, that materially adversely affects the performance of the Party claiming the event as an Uncontrollable Circumstance including but not limited to the following:

- (1) Acts of God, including, but not limited to floods, ice storms, blizzards, tornadoes, landslides, lighting and earthquakes (but not including reasonably anticipated weather conditions for the geographic area), riots insurrections, war or civil disorder affecting the performance of work, blockades, power or other utility failure, and fires or explosions.
- (2) The adoption of or change in any federal, state, or local laws, rules, regulations, ordinances, permits, or licenses, or changes in the interpretation of such laws, rules, regulations, ordinances, permits, or licenses by a court or public agency having appropriate jurisdiction after the date of the execution of this Agreement.
- (3) A suspension, termination, interruption, denial, or failure of renewal of any permit, license, consent, authorization, or approval essential to the construction of the Project.
- (4) Orders and/or judgment of any federal, state, or local court, administrative agency, or governmental body, provided, however, that the contesting in good faith by such Party of any such order and/or judgment shall not constitute or be construed to constitute a willful or negligent action or inaction of such Party.
- (5) Strikes or other such labor disputes shall not be considered an Uncontrollable Circumstance, unless such strike or labor dispute involves persons with whom the Parties have no employment relationship and the Parties, or either of them, cannot, using best efforts, obtain substitute performance.

### **ARTICLE III** **ALLOCATION OF DUTIES**

**Section 3.01. Design Phase Activities.** Design phase activities, including, but not limited to, field surveys, right of way plats, design, engineering, right-of-way acquisition, and other matters, shall be completed by the Parties as follows:

See attached Exhibit B – Allocation of Duties

**Section 3.02. Construction Phase Activities.** Construction phase activities, including, but not limited to, the bid process, preparation of contract documents, awarding of contract, construction inspection and surveying and other matters, shall be completed by the Parties as follows:

See attached Exhibit B – Allocation of Duties

**Section 3.03. Contract Award.** The Contract Documents shall be approved in writing,

which may be electronic, by the Parties prior to the solicitation of bids. The Contract Documents will require insurance coverage by the Contractor that will include the Parties as additional insured for the construction of the Project. In accordance with the applicable provisions of Minnesota Statutes, City will cause bids to be received by it for the construction of the Project and, subject to written approval, which may be electronic, by the County if the low responsible bidder's total is more than the Engineers Estimate for the County's cost share, shall award the contract for the construction of the Project to the lowest responsible bidder.

**Section 3.04. Project Construction.** Subject to Uncontrollable Circumstances, the Parties shall cause the Project to be constructed in accordance with the Contract Documents. The County shall have the right to review and approve of any proposed changes to the plans and specifications as they relate to County's cost participation prior to the work being performed.

**Section 3.05. Maintenance Upon Project Completion and Final Acceptance.** Highway maintenance shall be completed by the Parties, upon project completion and final acceptance of the Project, as follows:

The Parties agree to perform highway maintenance responsibilities that are consistent with the Carver County Cost Participation Policy, Maintenance Section, as shown in Exhibit D, unless superseded by a separate highway maintenance agreement between the Parties. The City will perform all maintenance responsibilities of the trail constructed as part of this Project. The City will perform all maintenance responsibilities on all roads under the City jurisdiction.

## **ARTICLE IV** **PROJECT COST SHARING**

**Section 4.01. Allocation.**

(a) The Project Costs for all items shall be divided between the City and County as follows:

See attached Exhibit C – Project Cost Sharing

(b) The Design Phase Professional Services Costs for all items shall be divided between the Parties as follows:

See attached Exhibit C – Project Cost Sharing

(c) The Construction Phase Professional Services Costs for all items shall be divided between the Parties as follows:

See attached Exhibit C – Project Cost Sharing

(d) All other costs including, but not limited to City/County Costs, shall be allocated between the Parties as follows:

See attached Exhibit C – Project Cost Sharing

**Section 4.02. Payments to Contractor.** The City shall make partial progress payments to the Contractor and, upon approval of both Parties hereto, the final payment to the Contractor in accordance with the Contract Documents. The County, or their designated County Representative, shall have the right to approve of any Change Orders prepared by the City that affect the County's cost share of the construction cost.

The County further agrees that it will participate in the settlement of any claim from the City's contractor for the Project that involve delays attributable to unreasonable delays in approval by the County for plan or specification changes deemed necessary by the City Engineer or staff. The amount of the County's participation in any such claim shall be commensurate with the percentage of delay directly attributable to County's actions.

**Section 4.03. Adjustments and Reconciliation.** To the extent that the actual value of any item included in an invoice cannot be accurately determined at the time of submission of the invoice, such item shall be invoiced on an estimated basis and an adjustment shall be made to reflect the difference between such estimated amount and the actual amount of such item on the next invoice after determination of the actual amount.

Prior to final acceptance of the Project, the designated City representative shall provide County with a reconciliation of all costs for the Project and the respective contributions of the Parties for the review and approval of the Parties.

**Section 4.04. Exclusive Responsibility.** All aspects of application for State of Minnesota for State and Federal Funds and the grant thereof by the State, are the exclusive responsibility of the City, including but not limited to the investment, expenditure, and allocation of such funds. It is specifically agreed that any interest on the investment of any such funds is the sole property of the City, to use as the City shall see fit.

**Section 4.05. Payment to City.** The County agrees to reimburse the City for costs incurred, pursuant to Section 4.01. Unless previously deposited as provided herein, the County is responsible to pay these monies to the City within thirty (30) days of being invoiced for costs incurred or services performed. Costs will be invoiced monthly and upon final acceptance of the Project by the Parties, unless an alternate schedule is mutually agreed upon in writing by the authorized representatives of the Parties.

After an award by City to the successful bidder on the Project, the City shall invoice the County to deposit with the City ninety-five (95) percent of the estimated County's share in the Project Costs within 30 days of execution of this Agreement.

**Section 4.06. Payment to County.** The City agrees to reimburse the County for costs incurred, pursuant to Section 4.01. The City is responsible to pay these monies to the County within thirty (30) days of being invoiced for costs incurred or services performed. Costs will be invoiced monthly and upon final acceptance of the Project by the Parties, unless an alternate schedule is

mutually agreed upon in writing by the authorized representatives of the Parties.

**ARTICLE V**  
**GENERAL PROVISIONS**

**Section 5.01. Notices.** All notices or communications required or permitted pursuant to this Agreement shall be either hand delivered or mailed to City and County, certified mail, return-receipt requested, at the following address:

**City:** Shane Fineran  
City Administrator  
City of Waconia  
201 S. Vine Street  
Waconia, MN 55387

**County:** Lyndon Robjent, PE  
County Engineer  
Carver County Public Works  
11360 Hwy 212 West, Suite 1  
Cologne, MN 55322

Either Party may change its address or authorized representative by written notice delivered to the other Party pursuant to this Section 5.01.

**Section 5.02. Counterparts.** This Agreement may be executed in more than one counterpart, each of which shall be deemed to be an original but all of which taken together shall be deemed a single instrument.

**Section 5.03. Survival of Terms, Representations and Warranties.** The representations, warranties, covenants, and agreements of the Parties under this Agreement, and the remedies of either Party for the breach of such representations, warranties, covenants, and agreements by the other Party shall survive the execution and termination of this Agreement. The terms of Sections 3.05, 5.14, 5.15, 5.16 and 5.17 shall survive the expiration, termination or withdrawal from this Agreement.

**Section 5.04. Non-Assignability.** Neither the City nor the County shall assign any interest in this Agreement nor shall transfer any interest in the same, whether by subcontract, assignment or novation, without the prior written consent of the other Party. Such consent shall not be unreasonably withheld.

**Section 5.05. Alteration.** It is understood and agreed that the entire Agreement between the Parties is contained herein and that this Agreement supersedes all oral agreements and negotiations between the Parties relating to the subject matter hereof. All items referred to in this

Agreement are incorporated or attached and are deemed to be part of this Agreement. Any alteration, variation, modification or waiver of the provisions of the Agreement shall be valid only after it has been reduced to writing and duly signed by all Parties.

**Section 5.06. Waiver.** The waiver of any of the rights and/or remedies arising under the terms of this Agreement on any one occasion by any Party hereto shall not constitute a waiver or any rights and/or remedies in respect to any subsequent breach or default of the terms of this Agreement. The rights and remedies provided or referred to under the terms of this Agreement are cumulative and not mutually exclusive.

**Section 5.07. Severability.** The provisions of this Agreement are severable. If any paragraph, section, subdivision, sentence, clause or phrase of this Agreement is for any reason held to be contrary to law, or contrary to any rule or regulation having the force and effect of law, such decision shall not affect the remaining portions of this Agreement.

**Section 5.08. Interpretation According to Minnesota Law.** The Laws of the State of Minnesota shall apply to this Agreement.

**Section 5.09. Final Payment.** Before final payment is made to the Contractor, the Contractor shall provide a certificate of compliance from the Commissioner of Revenue certifying that the Contractor and any out-of-state subcontractors have complied with the provisions of Minnesota Statutes, Section 290.92.

**Section 5.10. Headings.** The headings to the various sections of this Agreement are inserted only for convenience of reference and are not intended, nor shall they be construed, to modify, define, limit, or expand the intent of the Parties as expressed in this Agreement.

**Section 5.11. Further Actions.** The Parties agree to execute such further documents and take such further actions as may reasonably be required or expedient to carry out the provisions and intentions of this Agreement, or any agreement or document relating hereto or entered into in connection herewith.

**Section 5.12. Parties in Interest.** This Agreement shall be binding upon and inure solely to the benefit of the Parties hereto and their permitted assigns, and nothing in this Agreement, express or implied, is intended to confer upon any other person any rights or remedies of any nature under or by reason of this Agreement.

**Section 5.13. Employees.** It is further agreed that any and all full-time employees of County and all other employees of said County engaged in the performance of any work or services required or provided for herein to be performed by the County shall be considered employees of County only and not of City and that any and all claims that may or might arise under Workman's Compensation Act of the State of Minnesota on behalf of said employees while so engaged and any and all claims made by any third Parties as a consequence of any act or omission on the part of County employees while so engaged on any of the work or services provided to be rendered herein shall be the sole obligation and responsibility of County.

It is further agreed that any and all full-time employees of City and all other employees of said City engaged in the performance of any work or services required or provided for herein to be performed by City shall be considered employees of City only and not of County and that any and all claims that may or might arise under Workman's Compensation Act of the State of Minnesota on behalf of said employees while so engaged and any and all claims made by any third Parties as a consequence of any act or omission on the part of said City employees which so engaged on any of the work or services to be rendered herein shall be the sole obligation and responsibility of City.

**Section 5.14. Indemnification.** The Parties' total liability under this Agreement shall be governed by Minn. Statutes, Section 471.59, Subd. 1a.

Each Party agrees that it will be responsible for the acts or omissions of its officials, agents, and employees, and the results thereof, in carrying out the terms of this Agreement, to the extent authorized by law and shall not be responsible for the acts/omissions of the other Party and the results thereof. For purposes of determining total liability for damages, the participating governmental units are considered to be a single governmental unit, the total liability of which shall not exceed the limits for a single governmental unit as provided in Minn. Statutes, Section 466.04, Subd. 1.

Each Party agrees to defend, hold harmless, and indemnify the other Party, its officials, agents, and employees, from any liability, loss, or damages the other Party may suffer or incur as the result of demands, claims, judgments, or cost arising out of or caused by the indemnifying Party's negligence in the performance of its respective obligations under this Agreement. This provision shall not be construed nor operate as a waiver of any applicable limitation of liability, defenses, immunities, or exceptions by statute or common law.

To the full extent permitted by law, actions by the Parties pursuant to this Agreement are intended to be and shall be construed as a "cooperative activity" and it is the intent of the Parties that they shall be deemed a "single governmental unit" for the purposes of liability, all as set forth in Minnesota Statutes, Section 471.59, Subd. 1a(a); provided further that for purposes of that statute, each Party to this Agreement expressly declines responsibility for the acts or omissions of the other Party.

The Parties of this Agreement are not liable for the acts or omissions of the other participants to this Agreement except to the extent to which they have agreed in writing to be responsible for acts or omissions of the other Parties.

**Section 5.15. Records – Availability and Access**

- A. Pursuant to Minnesota Statutes, Section 16C.05, Subd. 5, the City agrees that the County, the State Auditor, or any of their duly authorized representatives at any time during normal business hours and as often as they may reasonably deem necessary, shall have access to and the right to examine, audit, excerpt, and transcribe any books, documents, papers, records, etc., which are pertinent to the accounting practices and procedures of the City and involve transactions relating to this Agreement.

City agrees to maintain these records for a period of six years from the date of termination of this Agreement.

- B. Pursuant to Minnesota Statutes, Section 16C.05, Subd. 5, the County agrees that the City, the State Auditor, or any of their duly authorized representatives at any time during normal business hours and as often as they may reasonably deem necessary, shall have access to and the right to examine, audit, excerpt, and transcribe any books, documents, papers, records, etc., which are pertinent to the accounting practices and procedures of the County and involve transactions relating to this Agreement.

County agrees to maintain these records for a period of six years from the date of termination of this Agreement.

**Section 5.16. Data Practices.** Each Party, its employees, agents, owners, partners, and subcontractors agree to abide by the provisions of the Minnesota Government Data Practices Act, Minnesota Statutes, Chapter 13 and implementing regulations, if applicable, and all other applicable state and federal laws, rules, regulations and orders relating to data privacy or confidentiality, and as any of the same may be amended.

**Section 5.17. Nondiscrimination.** During the performance of this Agreement, the City and the County agree to the following: No person shall, on the grounds of race, color, religion, age, sex, disability, marital status, public assistance status, criminal record, creed or national origin be excluded from full employment right in, participation in, be denied the benefits of or be otherwise subjected to discrimination under any and all applicable Federal and State laws against discrimination.

**Section 5.18. Default and Withdrawal.** Default in this Agreement may occur when a Party fails to perform any of the provisions of this Agreement or so fails to administer the work as to endanger the performance of the Agreement. Unless the Party's default is excused by the non-defaulting Party, the non-defaulting Party may, upon written notice to the defaulting Party representative listed herein, cancel this Agreement in its entirety as indicated below.

Any Party may withdraw from this Agreement with or without cause by providing thirty (30) days' prior written notice to the other Parties herein. Only the governing bodies of the Participating Parties have authority to act pursuant to this provision of the Agreement.

Each Party to this agreement reserves the right to withdraw from and cancel this agreement within 30 days from the opening of bids for the project in the event either or both Parties consider any or all bids unsatisfactory; the withdrawal from or cancellation of the agreement to be accomplished by either or both Parties within 30 days of opening of bids by serving a written notice thereof upon the other, unless this right is waived by both Parties in writing.

**Section 5.19. Third Party.** This Agreement does not create any rights, claims or benefits inuring to any person that is not a Party hereto nor create or establish any third Party beneficiary.

IN TESTIMONY WHEREOF, The Parties hereto have caused these presents to be executed.

*City of Waconia, Minnesota*

*County of Carver, Minnesota*

\_\_\_\_\_  
Mayor, TIM LITFIN

\_\_\_\_\_  
County Board Chair

Date: APRIL 6, 2026

Date: \_\_\_\_\_

*Attest:*

*Attest:*

\_\_\_\_\_  
Administrator, SHANE FINERAN

\_\_\_\_\_  
County Administrator

Date: APRIL 6, 2026

Date: \_\_\_\_\_

*Approved As To Form:*

*Approved As To Form:*

\_\_\_\_\_  
Attorney

\_\_\_\_\_  
County Attorney

Date: \_\_\_\_\_

Date: \_\_\_\_\_

Exhibit A - Project Location

County State Aid Highway 10 Future Regional Linking Trail Project



## **County State Aid Highway 10 Future Regional Linking Trail Project**

### **Exhibit B – Allocation of Duties**

#### **Design Phase Activities**

City will complete all design phase activities of the Project and procure necessary Design Phase Professional Services.

It is mutually agreed that the City has the authority to acquire all fee title, permanent and temporary easements required for the Project. The City shall notify the County, no later than fourteen (14) days prior to city council action to approve of eminent domain, if the land acquisition for the Project cannot be acquired by direct purchase. County does not object to the City, subject to authorization from its city council, from acquiring any land that cannot be acquired by direct purchase through the eminent domain process under Minnesota Statutes Chapter 117. Subject to authorization from its city council, County does not object to the City exercising the power of eminent domain related to the Project in the City's name. The City shall not exercise the power of eminent domain related to the Project in the County's name.

It is mutually agreed upon that County staff will need to be involved in giving direct input and direction to City's consultant for the design of County infrastructure improvements.

#### **Construction Phase Activities**

City will complete all construction phase activities of the Project and procure necessary Construction Phase Professional Services, and that City will provide for the construction inspection services for all City utilities constructed with the Project.

## County State Aid Highway 10 Future Regional Linking Trail Project

### Exhibit C – Project Cost Sharing

The County and City agree that items not specifically covered by this agreement will be cost shared by the parties in accordance with the current version of the Carver County Cost Participation Policy, for a Conventional Project, which is attached hereto as Exhibit D. County and City agree to cost share as follows:

#### Project Costs

The County and City agree to cost share Project Costs in accordance with the Carver County Cost Participation Policy (Exhibit D) and augmented by the following:

1. The City has secured a Minnesota Department of Natural Resources (DNR) Local Trails Connections Program grant in the amount of \$175,000 for the Project.
2. The County and City agree to evenly split (50% County/50% City) total Project Costs after subtracting the DNR grant funding from the total Project Costs.
3. The County agrees to pay for all County requested improvements that are included in the Project, that the City does not deem necessary to carry out the scope of the Project. The Engineers Estimate and any Change Orders will show such County requested improvement costs for County approval.
4. The Parties agree that the Engineer's Estimate table shown in **Exhibit C1** represents an estimate of the total costs for the Project and serves as a guide to how these costs will be split by the Parties as well as how the Minnesota Department of Natural Resources (DNR) Local Trails Connections Program grant will be allocated.

#### Design and Construction Phase Professional Services Costs

The County and City agree to cost share Design and Construction Phase Professional Services Costs in accordance with the Carver County Cost Participation Policy (Exhibit D) and augmented by the following:

1. The County and City agree to evenly split (50% County/50% City) all right of way related professional services costs.
2. All remaining professional services costs will be split in accordance with the Carver County Cost Participation Policy (Exhibit D) and will be considered the same as engineering services.

#### Other Costs

The County and City agree to cost share Other Costs in accordance with the Carver County Cost Participation Policy (Exhibit D) and augmented by the following:

1. All remaining City direct and indirect costs of staff and other incidental costs will be split with the County in accordance with the Carver County Cost Participation Policy (Exhibit D) and will be considered the same as engineering services.
2. The City agrees to not bill County for direct and indirect internal staff costs for the Project in order to support the City administration of the project for County.
3. The County agrees to not bill City for direct and indirect internal staff costs for the Project in order to support the County administration of the project for County.

# Exhibit C1

## ENGINEER'S ESTIMATE

CSAH 10 Trail Addition  
 City of Waconia  
 BMI Project Number C14.120613  
 DNR C007-23-3B



Real People. Real Solutions.

Item No.	Item	Notes	Estimated Quantity	Unit	PARTICIPATING DNR C007-23-3B		Unit Price	Total Amount
					Quantity	Cost		
1	MOBILIZATION		1.00	LUMP SUM	1.00	\$35,000.00	\$35,000.00	\$35,000.00
2	SALVAGE PIPE APRON	[2]	4	EACH	4	\$1,900.00	\$475.00	\$1,900.00
3	SALVAGE SIGN TYPE C		2	EACH	2	\$600.00	\$300.00	\$600.00
4	SALVAGE SIGN TYPE SPECIAL		3	EACH	3	\$900.00	\$300.00	\$900.00
5	SALVAGE PIPE SEWER (STORM)	[2]	30	LIN FT	30	\$2,700.00	\$90.00	\$2,700.00
6	REMOVE BITUMINOUS PAVEMENT	[1]	971	SQ YD	971	\$6,797.00	\$7.00	\$6,797.00
7	EXCAVATION - COMMON	[EV]	250	CU YD	250	\$7,500.00	\$30.00	\$7,500.00
8	EXCAVATION - MUCK	[EV]	2285	CU YD	2285	\$57,125.00	\$25.00	\$57,125.00
9	EXCAVATION - SUBGRADE	[EV]	30	CU YD	30	\$900.00	\$30.00	\$900.00
10	COMMON EMBANKMENT	[CV]	5101	CU YD	5101	\$82,891.25	\$16.25	\$82,891.25
11	STABILIZING AGGREGATE	[CV]	30	CU YD	30	\$1,582.50	\$52.75	\$1,582.50
12	AGGREGATE BASE CLASS 5		714	CU YD	714	\$24,633.00	\$34.50	\$24,633.00
13	BITUMINOUS PATCHING MIXTURE		86	TON	86	\$12,319.50	\$143.25	\$12,319.50
14	TYPE SP 9.5 WEARING COURSE MIX (2,B)		305	TON	305	\$35,913.75	\$117.75	\$35,913.75
15	PREFABRICATED MODULAR BLOCK WALL		445	SQ FT	445	\$40,828.75	\$91.75	\$40,828.75
16	SPECIAL SURFACE FINISH		445	SQ FT	445	\$8,010.00	\$18.00	\$8,010.00
17	15" RC PIPE APRON		2	EACH	2	\$4,600.00	\$2,300.00	\$4,600.00
18	INSTALL PIPE APRON		4	EACH	4	\$14,000.00	\$3,500.00	\$14,000.00
19	15" RC PIPE SEWER CLASS V		67	LIN FT	67	\$5,075.25	\$75.75	\$5,075.25
20	21" RC PIPE SEWER CLASS III		11	LIN FT	11	\$1,078.00	\$98.00	\$1,078.00
21	36" SPAN RC PIPE-ARCH SEWER CL IIIA		48	LIN FT	48	\$19,200.00	\$400.00	\$19,200.00
22	88" SPAN RC PIPE-ARCH SEWER CL IIIA		14	LIN FT	14	\$28,000.00	\$2,000.00	\$28,000.00
23	INSTALL PIPE SEWER		30	LIN FT	30	\$2,550.00	\$85.00	\$2,550.00
24	CONNECT TO EXISTING STORM SEWER		4	EACH	4	\$6,512.00	\$1,628.00	\$6,512.00
25	ADJUST HYDRANT		1	EACH	1	\$1,000.00	\$1,000.00	\$1,000.00
26	ADJUST VALVE BOX		1	EACH	1	\$389.00	\$389.00	\$389.00
27	HYDRANT RISER		1	LIN FT	1.0	\$1,200.00	\$1,200.00	\$1,200.00
28	CASTING ASSEMBLY		4	EACH	4	\$5,800.00	\$1,450.00	\$5,800.00
29	CONSTRUCT DRAINAGE STRUCTURE DESIGN G		11	LIN FT	10.9	\$6,104.00	\$560.00	\$6,104.00
30	CONSTRUCT DRAINAGE STRUCTURE DESIGN 48-4020		4	LIN FT	4.1	\$2,685.50	\$655.00	\$2,685.50
31	RANDOM RIPRAP CLASS III		114.1	CU YD	114.1	\$17,514.35	\$153.50	\$17,514.35
32	6" CONCRETE WALK		180	SQ FT	180	\$2,790.00	\$15.50	\$2,790.00
33	CONCRETE CURB & GUTTER DESIGN B424		1535	LIN FT	1535	\$42,596.25	\$27.75	\$42,596.25
34	TRUNCATED DOMES		40	SQ FT	40	\$2,220.00	\$55.50	\$2,220.00
35	ORNAMENTAL FENCE DESIGN SPECIAL		32	LIN FT	32	\$12,968.00	\$405.25	\$12,968.00
36	TRAFFIC CONTROL SUPERVISOR		1	LUMP SUM	1.00	\$3,000.00	\$3,000.00	\$3,000.00
37	TRAFFIC CONTROL		1	LUMP SUM	1.00	\$8,000.00	\$8,000.00	\$8,000.00
38	INSTALL SIGN TYPE C		2	EACH	2	\$500.00	\$250.00	\$500.00
39	INSTALL SIGN TYPE SPECIAL		3	EACH	3	\$750.00	\$250.00	\$750.00
40	STORM DRAIN INLET PROTECTION		4	EACH	4	\$622.00	\$155.50	\$622.00
41	SILT FENCE, TYPE MS		3700	LIN FT	3700	\$12,025.00	\$3.25	\$12,025.00
42	SUBSOILING		2	ACRE	2	\$970.00	\$485.00	\$970.00
43	SOIL BED PREPARATION		2	ACRE	2	\$489.00	\$244.50	\$489.00
44	COMMON TOPSOIL BORROW		923	CU YD	923	\$27,690.00	\$30.00	\$27,690.00
45	ROLLED EROSION PREVENTION CATEGORY 20		5431	SQ YD	5431	\$16,293.00	\$3.00	\$16,293.00
46	SEED MIXTURE 25-131		160	POUND	160	\$720.00	\$4.50	\$720.00
47	SEED MIXTURE 25-141		178	POUND	178	\$801.00	\$4.50	\$801.00
48	HYDRAULIC BONDED FIBER MATRIX		18000	POUND	18000	\$22,500.00	\$1.25	\$22,500.00
<b>TOTAL CONSTRUCTION COST</b>						\$590,243.10		
<b>+25% SOFT COST</b>						\$147,560.78		\$147,560.78
<b>TOTAL PROJECT COST</b>						\$737,803.88		\$737,803.88
<b>DNR GRANT FUNDING</b>								\$175,000.00
<b>TOTAL PROJECT COST LESS DNR GRANT FUNDING</b>								\$562,803.88
<b>CITY AND COUNTY COST EACH AT 50/50 COST SPLIT</b>								\$281,401.94

**ENGINEER'S ESTIMATE**

CSAH 10 Trail Addition  
 City of Waconia  
 BMI Project Number C14.120613  
 DNR C007-23-3B



Real People. Real Solutions.

Item No.	Item	Notes	Estimated Quantity	Unit	PARTICIPATING DNR C007-23-3B		Unit Price	Total Amount
					Quantity	Cost		
1	MOBILIZATION		1.00	LUMP SUM	1.00	\$35,000.00	\$35,000.00	\$35,000.00
2	SALVAGE PIPE APRON	[2]	4	EACH	4	\$1,900.00	\$475.00	\$1,900.00
3	SALVAGE SIGN TYPE C		2	EACH	2	\$600.00	\$300.00	\$600.00
4	SALVAGE SIGN TYPE SPECIAL		3	EACH	3	\$900.00	\$300.00	\$900.00
5	SALVAGE PIPE SEWER (STORM)	[2]	30	LIN FT	30	\$2,700.00	\$90.00	\$2,700.00
6	REMOVE BITUMINOUS PAVEMENT	[1]	971	SQ YD	971	\$6,797.00	\$7.00	\$6,797.00
7	EXCAVATION - COMMON	[EV]	250	CU YD	250	\$7,500.00	\$30.00	\$7,500.00
8	EXCAVATION - MUCK	[EV]	2285	CU YD	2285	\$57,125.00	\$25.00	\$57,125.00
9	EXCAVATION - SUBGRADE	[EV]	30	CU YD	30	\$900.00	\$30.00	\$900.00
10	COMMON EMBANKMENT	[CV]	5101	CU YD	5101	\$82,891.25	\$16.25	\$82,891.25
11	STABILIZING AGGREGATE	[CV]	30	CU YD	30	\$1,582.50	\$52.75	\$1,582.50
12	AGGREGATE BASE CLASS 5		714	CU YD	714	\$24,633.00	\$34.50	\$24,633.00
13	BITUMINOUS PATCHING MIXTURE	86		TON			\$143.25	
14	TYPE SP 9.5 WEARING COURSE MIX (2,B)		305	TON	305	\$35,913.75	\$117.75	\$35,913.75
15	PREFABRICATED MODULAR BLOCK WALL		445	SQ FT	445	\$40,828.75	\$91.75	\$40,828.75
16	SPECIAL SURFACE FINISH		445	SQ FT	445	\$8,010.00	\$18.00	\$8,010.00
17	15" RC PIPE APRON	2		EACH			\$2,300.00	
18	INSTALL PIPE APRON		4	EACH	4	\$14,000.00	\$3,500.00	\$14,000.00
19	15" RC PIPE SEWER CLASS V	67		LIN FT			\$75.75	
20	21" RC PIPE SEWER CLASS III		11	LIN FT	11	\$1,078.00	\$98.00	\$1,078.00
21	36" SPAN RC PIPE-ARCH SEWER CL IIIA		48	LIN FT	48	\$19,200.00	\$400.00	\$19,200.00
22	88" SPAN RC PIPE-ARCH SEWER CL IIIA		14	LIN FT	14	\$28,000.00	\$2,000.00	\$28,000.00
23	INSTALL PIPE SEWER		30	LIN FT	30	\$2,550.00	\$85.00	\$2,550.00
24	CONNECT TO EXISTING STORM SEWER		4	EACH	4	\$6,512.00	\$1,628.00	\$6,512.00
25	ADJUST HYDRANT		1	EACH	1	\$1,000.00	\$1,000.00	\$1,000.00
26	ADJUST VALVE BOX		1	EACH	1	\$389.00	\$389.00	\$389.00
27	HYDRANT RISER		1	LIN FT	1.0	\$1,200.00	\$1,200.00	\$1,200.00
28	CASTING ASSEMBLY	4		EACH			\$1,450.00	
29	CONSTRUCT DRAINAGE STRUCTURE DESIGN G	10.9		LIN FT			\$560.00	
30	CONSTRUCT DRAINAGE STRUCTURE DESIGN 48-4020	4.1		LIN FT			\$655.00	
31	RANDOM RIPRAP CLASS III		114.1	CU YD	114.1	\$17,514.35	\$153.50	\$17,514.35
32	6" CONCRETE WALK		180	SQ FT	180	\$2,790.00	\$15.50	\$2,790.00
33	CONCRETE CURB & GUTTER DESIGN B424	1535		LIN FT			\$27.75	
34	TRUNCATED DOMES		40	SQ FT	40	\$2,220.00	\$55.50	\$2,220.00
35	ORNAMENTAL FENCE DESIGN SPECIAL		32	LIN FT	32	\$12,968.00	\$405.25	\$12,968.00
36	TRAFFIC CONTROL SUPERVISOR		1	LUMP SUM	1.00	\$3,000.00	\$3,000.00	\$3,000.00
37	TRAFFIC CONTROL		1	LUMP SUM	1.00	\$8,000.00	\$8,000.00	\$8,000.00
38	INSTALL SIGN TYPE C		2	EACH	2	\$500.00	\$250.00	\$500.00
39	INSTALL SIGN TYPE SPECIAL		3	EACH	3	\$750.00	\$250.00	\$750.00
40	STORM DRAIN INLET PROTECTION		4	EACH	4	\$622.00	\$155.50	\$622.00
41	SILT FENCE, TYPE MS		3700	LIN FT	3700	\$12,025.00	\$3.25	\$12,025.00
42	SUBSOILING		2	ACRE	2	\$970.00	\$485.00	\$970.00
43	SOIL BED PREPARATION		2	ACRE	2	\$489.00	\$244.50	\$489.00
44	COMMON TOPSOIL BORROW		923	CU YD	923	\$27,690.00	\$30.00	\$27,690.00
45	ROLLED EROSION PREVENTION CATEGORY 20		5431	SQ YD	5431	\$16,293.00	\$3.00	\$16,293.00
46	SEED MIXTURE 25-131		160	POUND	160	\$720.00	\$4.50	\$720.00
47	SEED MIXTURE 25-141		178	POUND	178	\$801.00	\$4.50	\$801.00
48	HYDRAULIC BONDED FIBER MATRIX		18000	POUND	18000	\$22,500.00	\$1.25	\$22,500.00
<b>TOTAL CONSTRUCTION COST</b>						\$511,062.60		
<b>+25% SOFT COST</b>						\$127,765.65		\$127,765.65
<b>TOTAL PROJECT COST</b>						\$638,828.25		\$638,828.25
<b>DNR GRANT FUNDING</b>								\$175,000.00
<b>TOTAL PROJECT COST LESS DNR GRANT FUNDING</b>								\$463,828.25
<b>CITY AND COUNTY COST EACH AT 50/50 COST SPLIT</b>								<b>\$231,914.13</b>



# Carver County

## Division of Public Works

### COST PARTICIPATION POLICY

**Applicable to Cooperative Highway Projects between Carver County and Municipalities.**

Adopted by the Carver County Board of Commissioners on February 17, 1998.

Amended by the Carver County Board of Commissioners on February 13, 2007, and March 19, 2013.

#### A. Construction Cost Share – Conventional Project (Projects programmed in the County 5-year CIP.)

Project Items	County Share	Municipality Share	Note
Right of Way	By Negotiation	By Negotiation	1
Retaining Wall in lieu of right of way	Same %age as R/W	Same %age as R/W	
Clearing and Grubbing	100%	0%	
Grading	100%	0%	2
Aggregate Base and Surfacing	100%	0%	3
Parking Lanes on 4-lane or 6-lane road	0%	100%	4
Storm Sewer and Ponds/Treatment Basins	%age of Contributing Flow	%age of Contributing Flow	5
Culverts	100%	0%	
Concrete Sidewalk	0%>5000 Population 50%<5000 Population	100%>5000 Population 50%<5000 Population	6
Concrete Curb and Gutter and Pedestrian Ramps	0%>5000 Population 50%<5000 Population	100%>5000 Population 50%<5000 Population	7
Concrete Median and Median Curb	100%	0%	8
Concrete Driveway Entrances (Apron)	100%	0%	9
Municipal Utility Adjustment or Construction	0%	100%	
Roundabouts	By Leg	By Leg	
Traffic Signals	By Leg	By Leg	10
Intersection Lighting	By Leg	By Leg	11
Street Lighting	0%	100%	12
Bridges	By Negotiation	By Negotiation	
Trails along county highway	0% Local 50% Linking & Regional 100% Destination	100% Local 50% Linking & Regional 0% Destination	13
Trail Underpass/Overpass	0% Local 50% Linking & Regional 100% Destination	100% Local 50% Linking & Regional 0% Destination	14
Landscaping	25% up to State Aid Limit	75%	15
Aesthetic Treatments	0%	100%	16
Highway Signs	100%	0%	
Electronic/Specialty Signs	By Negotiation	By Negotiation	
Noise Walls	By Negotiation	By Negotiation	17
Mobilization	Pro-rated by const. share	Pro-rated by const. share	
Erosion Control	Pro-rated by const. share	Pro-rated by const. share	
Traffic Control	Pro-rated by const. share	Pro-rated by const. share	
Engineering Services	Pro-rated by const. share	Pro-rated by const. share	
Other items	By Negotiation	By Negotiation	



# Carver County

## Division of Public Works

### Conventional Project Notes

1. Fee title and permanent and temporary easements needed for projects on the existing county highway system or newly established or dedicated county highway system including the property needed for storm water treatment basins and wetland mitigation sites.
2. Includes grading and removal items. Applies to county roads and work necessary to tie in existing public street approaches. Enhancements to public streets approaches are the responsibility of the municipality. New public or private street approaches are the responsibility of the municipality.
3. Applies to county roads and work necessary to tie in existing public street approaches. Enhancements to public streets approaches are the responsibility of the municipality. New public or private street approaches are the responsibility of the municipality.
4. Includes grading, base and surfacing. Applies to county roads and work necessary to tie in existing public street approaches. Enhancements to public streets approaches are the responsibility of the municipality. New public or private street approaches are the responsibility of the municipality.
5. Includes catch basins, manholes, storm sewer pipes, outlet structures, grit chambers, and water quality and rate control ponds/basins. The county share is based on the ratio of contributing flow from the right of way to the total contributing flow.
6. Existing sidewalk impacted by the highway construction will be replaced in kind by the county.
7. Existing curb and gutter and pedestrian ramps impacted by the highway construction will be replaced in kind by the county.
8. The county pays for standard median design which is plain concrete. If a municipality requests decorative median the municipality pays the additional cost above the cost of a standard median.
9. Concrete aprons are installed at locations determined by the county. Driveways beyond the apron are constructed in-kind.
10. Applies to new and replacement traffic signals. Includes all components that make up a permanent warranted traffic control signal system with steel poles and mast arms installed at an intersection of a county highway and public roadway at an approved location by the county. The county pays 0% of a signal system at a private access/road. The municipality pays 100% of the furnishing and maintenance of electrical power to the traffic signal. The cost to modify, update or completely reconstruct the signal system will be shared at the same percentage as the original installation.
11. Designed to light an intersection for traffic safety purposes. Locations will be determined by the county.
12. Decorative type lighting along the roadway.
13. Applies to trails constructed with county road projects only. Stand alone trail projects are handled separately. Locations and descriptions are shown in the Carver County Comprehensive Plan and other related trail plans and policy documents. Applies to all costs associated with trail including but not limited to: grading, drainage, base, surfacing, pedestrian ramps, wetland mitigation due to trail impacts and additional right way needed for the trail. The county will only participate in trails constructed to meet State Aid Rules and Standards. Costs for major rehabilitation or replacement will be shared at the same percentage as the original installation. Townships are exempt from paying for trails.
14. Underpasses spanning 10 feet or more are considered bridges and will be added to the county bridge safety inspection program.
15. Landscaping items as approved by the county. State Aid limit is 5% of annual construction allotment.
16. Aesthetic items that do not serve a specific transportation use such as streetscaping, median plantings, decorative railing, ornamental fencing etc. All approved median plantings require irrigation.
17. Additional costs for decorative noise walls will be the responsibility of the requesting agency.



# Carver County

## Division of Public Works

### B. Construction Cost Share – Development Driven Project (Projects not programmed in the County 5-year CIP)

Project Items	County Share	Municipality Share	Note
Right of Way	0%	100%	1
Retaining Wall in lieu of right of way	Same %age as R/W	Same %age as R/W	
Clearing and Grubbing	100%	0%	
Grading	100% for through lane and shoulder (up to 44' wide).  50% for additional through lanes and median.  100% for county rd. to county rd. turn lanes.	0% for through lane and shoulder (up to 44' wide).  50% for additional through lanes and median.  100% for city st. to county rd. turn lanes and county rd. to city st. turn lanes	2
Aggregate Base and Surfacing	Same as Grading	Same as Grading	
Parking Lanes on 4-lane or 6-lane road	0%	100%	3
Storm Sewer and Ponds/Treatment Basins	%age of Contributing Flow	%age of Contributing Flow	4
Culverts	100%	0%	
Concrete Sidewalk	0%	100%	
Concrete Curb and Gutter and Pedestrian Ramps	0%	100%	
Concrete Median and Median Curb	50%	50%	5
Concrete Driveway Entrances (Apron)	100%	0%	6
Municipal Utility Adjustment or Construction	0%	100%	
Roundabouts	By Leg if meets warrants by opening.  By Leg up to 50% if meets warrants for design year.  0% if does not meet warrants for design year.	By Leg if meets warrants by opening.  By Leg but no less than 50% if meets warrants for design year.  100% if does not meet warrants for design year.	
Traffic Signals	By Leg if meets warrants by opening.  50% of County Legs if meets warrants for design year.  0% if does not meet warrants for design year.	By Leg if meets warrants by opening.  100% of City legs plus 50% of County Legs if meets warrants for design year.  100% if does not meet warrants for design year.	7
Intersection Lighting	By Leg	By Leg	8
Street Lighting	0%	100%	9
Bridges	By Negotiation	By Negotiation	



# Carver County

## Division of Public Works

Trails along county highway	0% Local 50% Linking & Regional 100% Destination	100% Local 50% Linking & Regional 0% Destination	10
Pedestrian Underpass/Overpass	0%	100%	11
Landscaping	0%	100%	12
Aesthetic Treatments	0%	100%	13
Highway Signs	100%	0%	
Electronic/Specialty Signs	By Negotiation	By Negotiation	
Noise Walls	0%	100%	14
Mobilization	Pro-rated by const. share	Pro-rated by const. share	
Erosion Control	Pro-rated by const. share	Pro-rated by const. share	
Traffic Control	Pro-rated by const. share	Pro-rated by const. share	
Engineering Services	Pro-rated by const. share	Pro-rated by const. share	
Other items	By Negotiation	By Negotiation	

### Development Driven Project Notes

1. Fee title and permanent and temporary easements needed for projects on the existing county highway system or newly established or dedicated county highway system including the property needed for storm water treatment basins and wetland mitigation sites. The cost share for right of way needed outside the boundaries of a development plat will be negotiated.
2. Includes grading and removal items. Enhancements to public streets approaches are the responsibility of the municipality. New public or private street approaches are the responsibility of the municipality.
3. Includes grading, base and surfacing. Applies to county roads and work necessary to tie in existing public street approaches. Enhancements to public streets approaches are the responsibility of the municipality. New public or private street approaches are the responsibility of the municipality.
4. Includes catch basins, manholes, storm sewer pipes, outlet structures, grit chambers, and water quality and rate control ponds/basins. The county share is based on the ratio of contributing flow. County share is based on the contributing flow from the right of way less roadway surface areas that the municipality pays for. The municipality share is the contributing flow from outside the right of way plus roadway surface area the municipality pays for. Costs to replace elements of storm sewer systems will be shared at the same percentage as the original installation.
5. The county pays for standard median design which is plain concrete. If a municipality requests decorative median the municipality pays the additional cost above the cost of a standard median.
6. Concrete aprons are installed at locations determined by the county. Driveways beyond the apron are constructed in-kind.
7. Applies to new and replacement traffic signals. Includes all components that make up a permanent warranted traffic control signal system with steel poles and mast arms installed at an intersection of a county highway and public roadway at an approved location by the county. To meet signal warrants, the intersection must meet either the four hour or the eight hour vehicular volume warrant standard. The county pays 0% of a signal system at a private access/road. The municipality pays 100% of the furnishing and maintenance of electrical power to the traffic signal. The cost to modify, update or completely reconstruct the signal system will be shared at the same percentage as the original installation.
8. Designed to light an intersection for traffic safety purposes. Locations will be determined by the county.
9. Decorative type lighting along the roadway.
10. Applies to trails constructed with county road projects only. Locations and descriptions are shown in the Carver County Comprehensive Plan and other related trail plans and policy documents. Costs associated with trail include grading, drainage, base, surfacing, pedestrian ramps, wetland mitigation due to trail impacts and additional right way needed for the trail. The county will only participate in trails constructed to meet State Aid Rules and Standards. Costs for major rehabilitation or replacement will be shared at the same percentage as the original installation.
11. Underpasses spanning 10 feet or more are considered bridges and will be added to the county bridge safety inspection program.
12. Landscaping items as approved by the county.
13. Aesthetic items that do not serve a specific transportation use such as streetscaping, median plantings, decorative railing, ornamental fencing etc. All approved median plantings require irrigation.
14. Additional costs for decorative noise walls will be the responsibility of the requesting agency.



## *Carver County*

### *Division of Public Works*

- C. Maintenance - Maintenance of county highways constructed under this policy will be as follows unless specified differently in a separate maintenance agreement.**
1. The county is responsible for maintenance of the county highway between curbs or between outside edges of shoulders. This includes but is not limited to snow and ice control, patching, crack sealing, seal coating, pavement rehabilitation, shouldering, striping and sign replacement. In addition, the county is responsible for routine maintenance outside the edge of shoulder and within the right of way of a rural county highway. The county may enter into agreements with municipalities to perform highway maintenance.
  2. The municipality is responsible for maintenance of the boulevard, landscaped median, trees, shrubs, irrigation systems, sidewalk, retaining walls, steps, aesthetic treatments, and other urban appurtenances within the right-of-way of an urban county highway.
  3. The county is responsible for maintenance of bridges and culverts on the county route.
  4. The municipality is responsible for maintenance of its utilities and storm sewer systems including detention/treatment basins. Costs to replace elements of storm sewer systems will be shared at the same percentage as the original installation.
  5. The county is responsible for maintaining roundabouts with the exception of island landscaping and aesthetic treatments which are the responsibility of the municipality.
  6. Unless stipulated by special agreement, the county will own and is responsible for maintaining traffic signal systems (with the exception of the attached lighting) at county road intersections with local public roadways and private streets. The municipality is responsible for maintaining the signal lighting and the electrical power to the signal system. The cost to modify, update or completely reconstruct the signal system will be shared at the same percentage as the original installation.
  7. The municipality is responsible for maintenance of intersection lighting at a county road and local road intersection. The county is responsible for maintenance of intersection lighting at a county road and county road intersection.
  8. The municipality is responsible for the maintenance of street lights.
  9. The municipality is responsible for maintaining trails within the county highway right-of-way. Costs for major rehabilitation or replacement will be shared at the same percentage as the original installation.
  10. The municipality is responsible for maintaining pedestrian underpasses and overpasses.
  11. The county is responsible for maintaining highway signs.
  12. The county is responsible for maintaining electronic/specialty signs. The costs of maintenance will be shared at the same percentage as the original installation.
  13. Maintenance of noise walls is the responsibility of the agency paying for the initial installation.



**REQUEST FOR CITY COUNCIL ACTION**

<b>Meeting Date:</b> April 6, 2026	
<b>Item Name:</b> 8.5. Accept Proposal for Phase 2 Environmental Site Assessment for TH 5 Phase 2 Corridor Improvements	
<b>Originating Dept:</b> Public Services	
<b>Presented By:</b> Jon Haukaas	
<b>Previous Council Action:</b> Resolution No. 2025-256 Authorizing the Proposal for Modified Phase 1 Environmental Site Assessment in support of the Trunk Highway 5 Phase 2 Corridor Improvements	
<b>Item Type:</b>	Consent
<b>RECOMMENDATIONS/COUNCIL ACTION/MOTION REQUESTED:</b> Adopt Resolution No. 2026-091 Authorizing the Proposal for Phase 2 Environmental Site Assessment in support of the Trunk Highway 5 Phase 2 Corridor Improvements	
<b>EXPLANATION OF AGENDA ITEM:</b>	
<p>Braun Intertec was hired to complete a Phase 1 Environmental Site Assessment (ESA) along the TH 5 Phase 2 corridor, as required by MnDOT. The Phase 1 ESA is a desktop review and identifies potential environmental concerns and determines whether a Phase 2 ESA is warranted. Phase 2 requires onsite soil sampling and preparation of a report. This report clarifies the anticipated levels of contaminants that may be encountered during construction and outlines the procedures for their proper handling. MnDOT has emphasized that completion of the Phase 2 ESA is mandatory for this project. Braun Intertec has submitted a proposal for the Phase 2 ESA with an estimated fee of \$43,741. The scope includes 12 borings and the collection and testing of 20 soil samples. Our engineering consultant will coordinate with Braun and MnDOT to develop a work plan that seeks to reduce costs where possible while remaining compliant with MnDOT requirements.</p> <p>Staff recommends acceptance of the proposal.</p>	
<b>ATTACHMENTS:</b>	
<ol style="list-style-type: none"> <li>1. Resolution No. 2026-091 Phase 2 ESA</li> <li>2. TH5 Phase 2 Drilling Investigation with Braun</li> </ol>	
<b>FINANCIAL IMPLICATIONS:</b>	<b>ADVISORY BOARD RECOMMENDATIONS:</b>
Funding Sources & Uses:	Planning Commission:
Budget Information:	Park Board:
x _____ Budgeted	Personnel Committee:
_____ Non-Budgeted	Other:
_____ Amendment Required	

**CITY OF WACONIA  
RESOLUTION NO. 2026-091**

**RESOLUTION AUTHORIZING ACCEPTANCE OF A PROPOSAL FOR  
PHASE 2 ENVIRONMENTAL SITE ASSESSMENT  
IN SUPPORT OF THE DESIGN OF TRUNK HIGHWAY FIVE  
PHASE II CORRIDOR IMPROVEMENTS**

**WHEREAS**, one of the City’s Priorities is to “manage, maintain, and improve our current and future physical assets”; and

**WHEREAS**, the City Council authorized a contract with Braun Intertec to complete a Modified Phase 1 Environmental Site Assessment (ESA) for the project on November 3, 2025; and

**WHEREAS**, the Modified Phase 1 Environmental Site Assessment (ESA) results ultimately recommended additional work that will be required for MnDOT approval in the form of a Phase 2 ESA to include onsite soil sampling and preparation of a report that will clarify the anticipated levels of contaminants that will likely be encountered during construction and how they need to be handled; and

**WHEREAS**, the City Consulting Engineer has negotiated a proposal and work plan with Braun Intertec to perform all services related to the Modified Phase 2 ESA as described in the attached proposal; and

**WHEREAS**, staff recommends the City accept the proposal to complete a Modified Phase 2 Environmental Site Assessment in support of the TH 5 Phase 2 Corridor design.

**NOW, THEREFORE, BE IT RESOLVED** That the City Council of the City of Waconia hereby authorizes acceptance of the proposal in the amount of \$43,741.00 to Braun Intertec of Bloomington, MN.

Adopted by the City Council of the City of Waconia this 6th day of April 2026.

\_\_\_\_\_  
Tim Litfin, Mayor

Attest: \_\_\_\_\_  
Jackie Schulze, Assistant City Administrator

March 23, 2026

Andrew Budde, PE  
**Bolton & Menk, Inc.**  
3507 High Point Drive North  
Building 1, Suite E130  
Oakdale, MN 55128

Re: Proposal for a Limited Phase II Drilling Investigation  
TH 5 Reconstruction  
Waconia, Minnesota

Dear Mr. Budde:

Braun Intertec Corporation appreciates the opportunity to submit this proposal to complete a Limited Phase II Drilling Investigation for the proposed Trunk Highway (TH) 5 in Waconia, Minnesota.

## Project Information

Braun Intertec Corporation (Braun Intertec) previously received authorization from Bolton & Menk, Inc. to conduct a Modified Phase I Environmental Site Assessment (ESA) for State Project 231-010-010 / 1002-131, which includes improvements to Trunk Highway (TH) 5 between TH 284 and Main Street in Waconia, Carver County, Minnesota. The project team is now seeking a qualified consultant to complete a Limited Phase II Drilling Investigation for the Corridor.

The proposed construction will consist of the reconstruction of TH 5 with a new roundabout and ponding on the south side of TH 5. The project includes Minnesota Department of Transportation (MnDOT) involvement and coordination.

## Purpose

The purpose of the Limited Phase II Drilling Investigation will be to investigate the Corridor for the potential presence, magnitude, and extent of contaminated soil and groundwater that may require management during construction. Data gathered during the Limited Phase II Drilling Investigation will also be used to aid in the design (i.e., engineering controls may include vapor barriers or pond lining to prevent infiltration).

## Scope of Services

Braun Intertec has completed a Modified Phase I Environmental Site Assessment (ESA) for the project. The Phase I ESA identified 44 sites with High, Medium, or Low potential for contamination, including 5 high, 26 medium, and 13 low potential sites.

Based upon the Modified Phase I ESA results, further investigation was warranted in areas of proposed significant project excavation and/or adjacent to sites with high and medium potential for contamination for material management planning in advance of construction. Findings may also assist with determining the need for liability assurance in advance of right of way (ROW) acquisition.

This proposal consists of costs to complete up to 12 environmental soil borings, with collection of up to 20 soil samples and 8 groundwater samples. Due to the presence of overhead power lines along the northwest side of TH 5, we have included costs for traffic control in the event that a lane closure is needed to perform the work.

Soil Samples:

Up to 20 soil samples (one to two per boring, depending on field findings) will be collected and analyzed for a combination of the following parameters:

- Volatile organic compounds (VOCs) using United States Environmental Protection Agency (EPA) Method 8260.
- Polyaromatic hydrocarbons (PAHs) using EPA Method 8270.
- Eight Resource Conservation and Recovery Act (RCRA) metals using EPA Methods 6020 and 7471.
- Diesel range organics (DRO) using the Wisconsin Department of Natural Resources (WDNR) Method.
- Gasoline range organics (GRO) using the WDNR Method.

Temporary monitoring wells will be installed at up to 8 soil boring locations. Prior to sampling the temporary monitoring wells, static groundwater levels in each monitoring well will be measured to the nearest 0.01 foot and recorded. Groundwater samples will be placed directly into laboratory-supplied containers, preserved appropriately, and submitted to the laboratory for chemical analysis.

Groundwater Samples:

For the purposes of this proposal, we assume that 8 groundwater samples will be collected from the temporary monitoring well and submitted to the laboratory for analysis of the following parameters:

- VOCs using EPA Method 8260.
- Semi-volatile organic compounds (SVOCs) using EPA Method 8270.
- Dissolved eight RCRA metals using EPA Methods 6020 and 7470.
- DRO using the WDNR Method.
- GRO using the WDNR Method.

Sample results will be presented in a report that will include figures, tables of analytical results, boring logs, and laboratory reports.

## Schedule

Assuming right of access agreements for the proposed ROW acquisition parcels can be obtained, we will work with you to determine a specific drilling date. Currently, we have capacity to complete drilling as soon as April.

We anticipate up to 3 days of drilling and receiving analytical laboratory reports within 2 weeks of sample receipt. We will provide Bolton & Menk, Inc. with the draft report within 6 weeks of receipt of the laboratory report.

## Cost

We will furnish the services described in this proposal for an estimated fee of **\$43,741**. A tabulation showing hourly and/or unit rates associated with our proposed scope of services is attached.

Our work may extend over several invoicing periods. As such, for work that is performed during the course of each invoicing period, we will submit partial progress invoices.

## General Remarks

We appreciate the opportunity to present this proposal to you and will be happy to meet with you to discuss our proposed scope of services further and clarify the various scope components.

The proposed fee is based on the scope of services described and the assumptions that our services will be authorized within 30 days and that others will not delay us beyond our proposed schedule.

Our services will be provided under the terms of the Subconsultant Master Agreement for Professional Services dated January 1, 2021.

To have questions answered or schedule a time to meet and discuss our approach to this project further, please contact Ted Feit at 952.995.2114 or via email at [tfeit@braunintertec.com](mailto:tfeit@braunintertec.com)

Sincerely,

**BRAUN INTERTEC CORPORATION**



Ted Feit, PG  
Associate Director, Senior Scientist



Joseph M. Foline, CHMM  
Senior Manager, Senior Scientist



**REQUEST FOR CITY COUNCIL ACTION**

<b>Meeting Date:</b> April 6, 2026																	
<b>Item Name:</b> 8.6. Accept Proposal for Geotechnical Services for the Downtown Phase 4 Reconstruction project																	
<b>Originating Dept:</b> Public Services																	
<b>Presented By:</b> Jon Haukaas																	
<b>Previous Council Action:</b> Resolution No. 2026-073 Authorizing the Award of the Contract for the 2026 Downtown Phase 4 Reconstruction Project																	
<b>Item Type:</b>	Consent																
<p><b>RECOMMENDATIONS/COUNCIL ACTION/MOTION REQUESTED:</b> Adopt Resolution No. 2026-092 Accepting the Proposal for Special Inspection and Testing Services for the Downtown Phase 4 Reconstruction project.</p> <p><b>EXPLANATION OF AGENDA ITEM:</b></p> <p>The City contracts with a third-party geotechnical firm to provide special inspection and testing services on each of our projects. For the Downtown Reconstruction projects, these services have also included vibration monitoring to help protect historic foundations within the project area. For Downtown Reconstruction Phase 4, the City's consulting engineering team solicited proposals from three firms to provide materials testing and vibration monitoring services. Each proposal includes the installation and monitoring of two vibration sensors located at St Joseph Church and Old City Hall from early May through the end of August. A summary of the proposals is as follows:</p> <table border="1" style="width:100%; border-collapse: collapse; margin: 10px 0;"> <thead> <tr> <th style="width:15%;">Firm</th> <th style="width:20%;">Materials Testing</th> <th style="width:20%;">Vibration Monitoring</th> <th style="width:20%;">Total Cost</th> </tr> </thead> <tbody> <tr> <td><b>AET</b></td> <td>\$36,076.00</td> <td>\$14,870.00</td> <td>\$50,946.00</td> </tr> <tr> <td><b>Braun</b></td> <td>\$39,336.00</td> <td>\$23,520.00</td> <td>\$62,856.00</td> </tr> <tr> <td><b>Haugo</b></td> <td>\$31,285.00</td> <td>\$43,300.00</td> <td>\$74,585.00</td> </tr> </tbody> </table> <p>AET offered the lowest total cost and previously completed this work successfully on Phase 3. Staff recommends approval of the resolution authorizing acceptance of the proposal from American Engineering Testing, Inc.</p> <p><b>ATTACHMENTS:</b></p> <ol style="list-style-type: none"> <li>1. Resolution No. 2026-092 Inspection and Testing Services for Downtown Phase 2</li> <li>2. American Engineering Proposals</li> </ol>		Firm	Materials Testing	Vibration Monitoring	Total Cost	<b>AET</b>	\$36,076.00	\$14,870.00	\$50,946.00	<b>Braun</b>	\$39,336.00	\$23,520.00	\$62,856.00	<b>Haugo</b>	\$31,285.00	\$43,300.00	\$74,585.00
Firm	Materials Testing	Vibration Monitoring	Total Cost														
<b>AET</b>	\$36,076.00	\$14,870.00	\$50,946.00														
<b>Braun</b>	\$39,336.00	\$23,520.00	\$62,856.00														
<b>Haugo</b>	\$31,285.00	\$43,300.00	\$74,585.00														
<b>FINANCIAL IMPLICATIONS:</b>																	
Funding Sources & Uses:	<b>ADVISORY BOARD RECOMMENDATIONS:</b>																
Budget Information:																	
x Budgeted	Planning Commission:																
	Park Board:																

<p>Non-Budgeted Amendment Required</p>	<p>Personnel Committee: Other:</p>
--	--

**CITY OF WACONIA  
RESOLUTION NO. 2026-092**

**RESOLUTION AUTHORIZING APPROVAL OF  
PROPOSAL FOR SPECIAL INSPECTION AND TESTING SERVICES  
FOR THE DOWNTOWN PHASE 4 RECONSTRUCTDION PROJECT**

**WHEREAS**, one of the City’s Priorities is to “manage, maintain, and improve our current and future physical assets”; and

**WHEREAS**, it is desirable for the city to contract directly with a third party for a geotechnical construction observation, soils testing, and recommendations during construction projects; and

**WHEREAS**, the City Consulting Engineer has solicited proposals from three firms to perform the required special inspections and testing associated with the project; and

**WHEREAS**, staff is recommending acceptance of the proposal from American Engineering Testing, Inc. proposal for anticipated services in an amount of \$50,946.00 for the materials testing and vibration monitoring on the project; and

**WHEREAS**, upon approval the Public Services Director may execute the acknowledgement and agreement for services document with American Engineering Testing, Inc.

**NOW, THEREFORE, BE IT RESOLVED** That the City Council of the City of Waconia hereby authorizes approval of the agreement for services with American Engineering Testing, Inc. for special inspections and testing associated with the Downtown Phase 4 Reconstruction project.

Adopted by the City Council of the City of Waconia this 6<sup>th</sup> day of April 2026.

\_\_\_\_\_  
Tim Litfin, Mayor

Attest: \_\_\_\_\_  
Jackie Schulze, Assistant City Administrator

March 11, 2026

City of Waconia  
201 South Vine Street  
Waconia, MN 55387



c/o Bolton & Menk, Inc.  
2638 Shadow Lane, Suite 200  
Chaska, MN 55318

Attn: Shane Fineran – Owner Representative  
([sfineran@waconia.org](mailto:sfineran@waconia.org))

Colton Lee – Municipal Project Engineer  
([colton.lee@bolton-menk.com](mailto:colton.lee@bolton-menk.com))

RE: Special Inspection and Construction Testing Services Proposal  
Waconia Downtown Phase 4 - Testing  
1 W. 1<sup>st</sup> Street  
Waconia, MN  
AET Proposal No. P-0051238

Dear Mr. Fineran and Mr. Lee:

American Engineering Testing, Inc. (AET) is pleased to offer Special Inspection and Construction Testing Services to City of Waconia c/o Bolton & Menk Inc. (hereafter referred to as the Client) for the referenced project. This proposal has been prepared in response to a recent request by Colton Lee from Bolton & Menk Inc., dated March 4, 2026 and describes our understanding of the project, our anticipated scope of services, our unit rates, and an estimated total fee to perform these services.

## GEOTECHNICAL INFORMATION

A geotechnical exploration and analysis was performed for this project by Haugo GeoTechnical Services (Haugo). The results were presented in their Geotechnical Exploration Report, dated July 23, 2024 (Haugo Project/Report No. 21-0538). In the report, the site soil profile is generalized as varying thickness of fill and/or buried topsoil underlain predominantly by clayey glacial till soils. Refer to that report for more details regarding site conditions and recommendations.

## PROJECT INFORMATION

We understand the proposed construction will be reconstruction of utilities and pavements in Phase 4. Including 1<sup>st</sup> Street W., 1<sup>st</sup> Street E., 2<sup>nd</sup> Street E. and Elm Street S.

550 Cleveland Avenue North | Saint Paul, MN 55114

Phone (651) 659-9001 | (800) 972-6364 | Fax (651) 659-1379 | [teamAET.com](http://teamAET.com) | AA/EEO

This document shall not be reproduced, except in full, without written approval from American Engineering Testing, Inc.

## INFORMATION

Project documents provided to assist us in preparing this proposal included the following:

- Project Civil Plans, dated February 2, 2026.
- Project Manual, dated February 2, 2026.

## SCOPE OF SERVICES

Based on discussions with Colton Lee from Bolton & Menk Inc., and our review of the available plans and specifications, our anticipated scope of services is outlined below.

### **Excavation Observations and Soil Testing**

During excavation for the pavement excavations, and utility trench excavations, an Engineer will visit the site on an on-call basis to perform the following services:

- Observe the soils in the bottoms of the excavations completed at that time.
- Evaluate the suitability of the soils present in the excavations to support the anticipated fill, structural loads and pavements.

During placement of fill in the pavement excavations, and utility trench excavations, an Engineering Technician will visit the site on an on-call basis to test the compaction of the fill. The technician will perform the following services:

- In-place field density tests to evaluate the compaction of the fill soils using the nuclear density gauge method.
- Standard Proctor tests for each different type of fill encountered at the test locations.
- Obtain samples of sand fill and/or aggregate base materials for sieve analysis tests.

We estimate 1 trips will be required to complete the observations. We estimate 11 trips will be required to perform the compaction testing of the fill soils.

### **Bituminous Subgrade Proof Roll Observations and Testing**

During or after final grading of the pavement subgrade soils, AET personnel will observe proof rolling of the pavement subgrade soils. These observations will be performed by a Staff Engineer on an on-call basis. Our scope of services will include the following:

- Observe the reaction/stability of the pavement subgrade soils as they are proof rolled by a loaded, tandem-axle dump truck.
- Evaluate the subgrade deflections under the wheel loads, and mark areas of excessive deflection. Areas of excessive deflection will be shown to personnel from the contractor and/or their subcontractors.
- Provide recommendations for correction of the unstable subgrade soils.

After placement of the Class 5 aggregate base, an experienced Engineering Technician from our firm will test the compaction of these materials using the nuclear density gauge method, or by performing DCP testing. The nuclear density gauge test results will be compared to the Standard Proctor maximum dry density.

We estimate 1 trip will be required to complete the proof roll observations of the pavement subgrades and 1 trip will be required for aggregate base compaction testing services.

### **Concrete Testing**

AET personnel will perform testing of concrete on an on-call basis when requested by the contractor. These services will be performed by an experienced Engineering Technician at the frequencies required by the project specifications. On site visits when we are observing reinforcing steel, we will have the same AET personnel remain at the site to perform testing of the concrete, thus reducing mobilization charges. Our services will include the following:

- Document that the correct mix is delivered to the site by checking the delivery slips.
- Test the slump of the plastic concrete delivered to the site.
- Test the air content of the plastic concrete delivered to the site.
- Measure the temperature of the plastic concrete delivered to the site.
- Compare the test results to the requirements of the project specifications.

Any discrepancies from the project specifications will be brought to the attention of the contractor and/or their subcontractor. Daily field reports of our observations and testing will be available to the contractor and other authorized personnel at the site.

During placement of the concrete, an experienced Engineering Technician will also cast test cylinders for compressive strength testing. Project specifications require that one set of cylinders be cast for every 100 cubic yards (or fraction thereof) of each type of concrete placed each day. Each set will consist of five cylinders; one which will be tested after 7 days and three which will be tested after 28 days. The fifth cylinder will be held in reserve for future testing, if required. AET will also pick up the cylinders from the site and return them to our laboratory for moist curing and testing. The results of our compressive strength tests will be presented periodically, as they become available.

We estimate 10 trips will be required for testing of non-reinforced concrete elements.

### **Bituminous Observations and Testing**

When placement of the bituminous base and wear layers begins, an experienced Engineering Technician will make site visits on an on-call basis to observe the placement and rolling of the bituminous layers and to perform testing of the bituminous. The technician will perform the following services:



- Measure the temperature of the bituminous as it is placed and while it is being rolled.
- Measure the thickness of the bituminous layer while it is being rolled.
- Help to establish a rolling pattern each day by observing the number of passes the roller makes over the bituminous, and measuring the density of the bituminous during the rolling to evaluate how many passes are needed to reach the maximum density.
- Obtain samples of the bituminous for laboratory testing.

We assume the paving will be performed in 2 lifts and assume that 2 trips will be performed for the above referenced observation and sampling services.

The samples retrieved from the site will be tested in our laboratory for MnDOT Gyratory properties, including:

- Gyratory density, Rice specific gravity, Asphalt Film Thickness (AFT), Coarse Aggregate Angularity (CAA), and Fine Aggregate Angularity (FAA).
- Asphalt extraction and aggregate gradation.

## REPORTING

Reports presenting the results of our observations and testing services will be provided periodically during the various phases of construction. At the completion of construction, we will issue a final report summarizing the results of all observations and testing services, if requested.

## ESTIMATED FEES

Our services will be provided on a unit cost basis according to the unit rates provided in the attached Fee Schedule. Our monthly invoices will be determined by multiplying the number of personnel hours or tests by their respective unit rates. We have also estimated a total cost which we anticipate will be required to complete the previously described observations and testing services. This estimated total cost is based on our experience with similar projects and our conversations with Colton Lee from Bolton & Menk Inc. Our estimated total cost is **\$36,076.00**. We refer you to the attached Fee Schedule for an itemization of how we arrived at this estimated cost. We reserve the right to review our estimate after reviewing the final project structural plans and project specifications.

We caution that this is only an estimated cost. Often, variations in the overall cost of the services occur due to reasons beyond our control, such as construction change orders, weather delays, changes in the contractor's schedule, unforeseen conditions or retesting of services. These variations will affect the actual invoice totals, either increasing or decreasing our total costs for the project from those estimated in this proposal. If more time or tests are required, additional fees may be needed to complete the project testing services. If less time or tests are needed, a cost savings will be realized. We will not, however, exceed the estimated total cost for the project without first obtaining your authorization.



## TERMS AND CONDITIONS

All AET Services are provided subject to the Terms and Conditions set forth in the enclosed Construction Service Agreement—Terms and Conditions, which, upon acceptance of this proposal, are binding upon you as the Client requesting Services, and your successors, assignees, joint ventures and third-party beneficiaries. Please be advised that additional insured status is granted only upon written acceptance of the proposal.

## ACCEPTANCE

AET requests written acceptance of this proposal in the Proposal Acceptance box below, but the following actions shall constitute your acceptance of this proposal together with the Terms and Conditions: 1) issuing an authorizing purchase order for any of the Services described in this proposal, 2) authorizing AET's presence on site, or 3) written or electronic notification for AET to proceed with any of the Services described in this proposal. Please indicate your acceptance of this proposal by signing below and returning a copy to us. When you accept this proposal, you represent that you are authorized to accept on behalf of the Client.

## GENERAL REMARKS

AET appreciates the opportunity to provide this service for you and looks forward to working with you on this project. If you have any questions or need additional information, please contact me.

Sincerely,  
**American Engineering Testing, Inc.**

Prepared By:

Handwritten signature of Jesse A. Mohler in black ink.

Jesse A. Mohler  
Engineer II / Project Manager  
Phone: 651.523.1276  
Email: [jmohler@teamAET.com](mailto:jmohler@teamAET.com)

Reviewed By:

Handwritten signature of Andrew T. Schmid, P.E. in black ink.

Andrew T. Schmid, P.E.  
Principal Engineer  
Phone: 651.523.1274  
Email: [aschmid@teamAET.com](mailto:aschmid@teamAET.com)

Attachments: Fee Schedule  
Construction Service Agreement – Terms and Conditions  
Certificate of Insurance  
W9



**ACCEPTANCE AND AUTHORIZATION: AET Proposal No. P-0051238**

SIGNATURE: \_\_\_\_\_

PRINTED NAME: TIM LITFIN, MAYOR

COMPANY: CITY OF WACONIA

ADDRESS: 201 VINE STREET SOUTH

PHONE NUMBER AND EMAIL: \_\_\_\_\_

DATE: APRIL 6, 2026

**INVOICING INFORMATION (Provide Company AP Department Information, if present.)**

AP CONTACT NAME: \_\_\_\_\_

BILLING/MAILING ADDRESS: \_\_\_\_\_

AP PHONE NUMBER AND INVOICE EMAIL: \_\_\_\_\_

P.O. NO./ PROJECT NO.: \_\_\_\_\_

March 6, 2026  
AET Proposal Number: P-0051286



## ACKNOWLEDGEMENT AND AGREEMENT OF SERVICES

The services of American Engineering Testing, Inc., (AET) have been requested for the referenced project by Colton Lee of Bolton & Menk, Inc. on March 4, 2026.

Understood information from the requesting party includes the following:

<b>Project Name:</b>	Waconia Reconstruction Phase 4 – Vibration Monitoring
<b>Project Address:</b>	32 1 <sup>st</sup> Street East and 9 1 <sup>st</sup> Street West Waconia, Minnesota
<b>Client:</b>	Bolton & Menk, Inc.
<b>Client Address:</b>	2638 Shadow Lane, Suite 200 Chaska, MN 55318
<b>Client Contact:</b>	Colton Lee, P.E.
<b>Client E-Mail:</b>	Colton.Lee@bolton-menk.com
<b>Client Phone:</b>	612-346-6059

## UNDERSTOOD SCOPE OF SERVICES

AET will update the previous vibration monitoring plan from Phase 3 to apply to Phase 4 and take into consideration the Old City Hall building at 9 West 1<sup>st</sup> Street which is listed on the National Register of Historic Places and the sensitive architecture of St. Joseph Catholic Church at 32 1<sup>st</sup> Street East.

AET will implement and perform vibration monitoring at agreed-upon adjacent structures and buildings near construction operations. The seismographs will be placed at the following properties:

1. 32 1<sup>st</sup> Street East – St. Joseph Catholic Church
2. 9 1<sup>st</sup> Street West – Old City Hall

We anticipate two seismographs monitoring vibrations from May 2026 through the end of August 2026 (4 months). If more monitoring is needed based on property or project owner request or a change in construction plans, AET will provide a change order for additional monitoring using the rates below. AET will submit weekly reports of vibration activity.

AET will immediately notify the contractor if the vibrations exceed 80% of the safe vibration level established for the structures and work with the contractor to submit a proposal for corrective action necessary to ensure that the specified limit is not exceeded or minimized for future activities.



## FEES

Our fees for services will be charged on a time and materials basis by our current schedule of fees, which is attached. For this Vibration Monitoring scope of services described above, the cost will not exceed \$14,870.00 without prior written approval.

This proposal is valid for 30 days from the date issued.

## TERMS/CONDITIONS

All AET Services are provided subject to the Terms and Conditions outlined in the enclosed Service Agreement—Terms and Conditions, which, upon acceptance of this proposal, are binding upon you as the Client requesting Services, and your successors, assignees, joint ventures, and third-party beneficiaries. Please be advised that additional insured status is granted upon acceptance of the proposal.

## ACCEPTANCE

AET requests written acceptance of this proposal in the Authorized Client Representative section, but the following actions shall constitute your acceptance of this proposal together with the Terms and Conditions and Amendments: 1) issuing an authorizing purchase order for any of the Services described above, 2) authorizing AET's presence on-site or 3) written or electronic notification for AET to proceed with any of the Services described in this proposal. Please indicate your acceptance of this proposal by signing below and returning a copy to us. When you accept this proposal, you represent that you are authorized to accept on behalf of the Client.

AET appreciates the opportunity to provide this service for you and looks forward to working with you on this project. If you have any questions or need additional information, please contact me.

Sincerely,

**AET Representatives:**

A handwritten signature in black ink that reads 'Christine M. Snider'.

Christine M. Snider  
Senior Project Manager  
csnider@teamAET.com  
651-399-7165

A handwritten signature in black ink that reads 'Andrew T. Schmid'.

Andrew T. Schmid, PE  
Principal Engineer  
aschmid@teamAET.com  
651-523-1274

Please see the next page for Acceptance and Authorization. Thank you.



**Acceptance and Authorization: AET Proposal No. P-0051286**

Signature: \_\_\_\_\_

Printed Name: \_\_\_\_\_

Company: \_\_\_\_\_

Address: \_\_\_\_\_

Phone Number: \_\_\_\_\_

Email \_\_\_\_\_

Date: \_\_\_\_\_

**Invoicing Information**

Provide Company AP Department Information, if present.

AP Contact Name: \_\_\_\_\_

Billing/Mailing Address: \_\_\_\_\_

AP Phone Number: \_\_\_\_\_

Invoice Email: \_\_\_\_\_

P.O. Number: \_\_\_\_\_

Client Project Number: \_\_\_\_\_

Attachments: AET Fee Estimate  
Service Agreement – Terms and Conditions  
Proof of Insurance  
W9



## REQUEST FOR CITY COUNCIL ACTION

<b>Meeting Date:</b>	April 6, 2026
<b>Item Name:</b>	8.7. 2026 Capital Equipment
<b>Originating Dept:</b>	Public Services
<b>Presented By:</b>	Mike Dressel
<b>Previous Council Action:</b>	Adopt Resolution No. 2025-286 Authorizing Staff to Solicit Pricing for 2026 Capital Projects and Acquisitions.
<b>Item Type:</b>	Consent
<b>RECOMMENDATIONS/COUNCIL ACTION/MOTION REQUESTED:</b> Adopt Resolution No. 2026-093 Authorizing Acquisition of Capital Equipment	
<b>EXPLANATION OF AGENDA ITEM:</b>	
<p>The 2026 Capital Improvement Plan includes \$25,000 for the purchase of a 10-ton tilt deck trailer (Project No. 882). In 2025, the City purchased a new CAT mini excavator weighing over 16,000 pounds. Currently, the City has only one trailer capable of legally transporting equipment of this weight. This trailer is also used for transporting the paver, asphalt roller, and other equipment, which creates scheduling challenges and limits operational efficiency. To address this need, staff is proposing the purchase of an additional 10-ton tilt deck trailer to be shared across departments for equipment transport. Staff obtained a quotation from Ziegler CAT for a 2026 Towmaster T-20DT drop-deck tilt trailer in the amount of \$23,592.34.</p>	
<p>The 2026 Capital Improvement Plan also includes \$60,000 for the purchase of two UTVs (Project No. 581). These UTVs will be primarily utilized by the Parks Department to transport seasonal staff, tow portable dumpsters for collecting refuse from park trash receptacles, and perform a variety of other maintenance tasks. Their use will help reduce mileage and wear on higher-cost Toolcat vehicles. Over the past several months, staff evaluated UTVs from two manufacturers and selected the John Deere XUV 845M HVAC model. At this time, staff is recommending the purchase of one UTV, with the intent to evaluate its performance prior to proceeding with the purchase of a second unit. Staff confirmed that there is no cost savings associated with purchasing both units at the same time. Staff obtained a quotation from Kibble Equipment for a 2026 John Deere Gator XUV 845M HVAC in the amount of \$30,726.57.</p>	
<p>Staff compared pricing through the Minnesota State Cooperative Purchasing Program and the Sourcewell Cooperative Purchasing Program to ensure the most competitive pricing was obtained for the equipment and recommends the following:</p>	
<p>2026 Towmaster T-20DT Drop-Deck Tilt Trailer from Ziegler Cat \$23,592.34 2026 John Deere Gator XUV 845M HVAC from Kibble Equipment \$30,726.57</p>	
<b>ATTACHMENTS:</b>	
<ol style="list-style-type: none"><li>1. Resolution No. 2026-093 Capital Equipment</li><li>2. Towmaster Drop Deck Tilt Trailer Quote</li></ol>	

3. John Deere Gator Quote

<b>FINANCIAL IMPLICATIONS:</b>	<b>ADVISORY BOARD RECOMMENDATIONS:</b>
Funding Sources & Uses: Budget Information: <input checked="" type="checkbox"/> Budgeted _____ Non-Budgeted _____ Amendment Required	Planning Commission: Park Board: Personnel Committee: Other:

**CITY OF WACONIA  
RESOLUTION NO. 2026-093**

**RESOLUTION AUTHORIZING ACQUISITION OF CAPITAL EQUIPMENT**

**WHEREAS**, one of the City’s Priorities is to “manage, maintain, and improve our current and future physical assets”; and

**WHEREAS**, the Public Services staff continually evaluates equipment needs in an effort to optimize use and improve efficiency of operations; and

**WHEREAS**, which more recent evaluation identified other equipment that will be provide better utilized and improve operations across multiple divisions; and

**WHEREAS**, the following list of equipment has been priced through the Minnesota State Cooperative Purchasing Program, Sourcewell Cooperative Purchasing Program and quotation to find the best pricing on the desired equipment; and

2026 Towmaster T-20DT Drop-Deck Tilt Trailer \$23,592.34  
2026 John Deere Gator XUV 845M HVAC \$30,726.57

**WHEREAS**, Staff recommends approval and authorization to purchase the requested equipment.

**NOW, THEREFORE, BE IT RESOLVED** That the City Council of the City of Waconia hereby authorizes acquisition of equipment from various vendors through quotation, Sourcewell Cooperative Purchasing Program and the State of Minnesota Cooperative Purchasing Program.

Adopted by the City Council of the City of Waconia this 6<sup>th</sup> day of April 2026.

\_\_\_\_\_  
Tim Litfin, Mayor

Attest: \_\_\_\_\_  
Jackie Schulze, Assistant City Administrator

**Customer:**  
 City of Waconia  
 MN State Bid 221693

**Trailer Description:**  
 Towmaster T-20DT Drop-Deck Tilt Trailer

**Attention:**  
 Ziegler Contact:  
 Corey Knuppel

**ESTIMATED COMPLETION - JUNE/JULY 2026**  
**LEAD-TIME IS SUBJECT TO CHANGE!**

**T-20DT Drop-Deck Tilt**

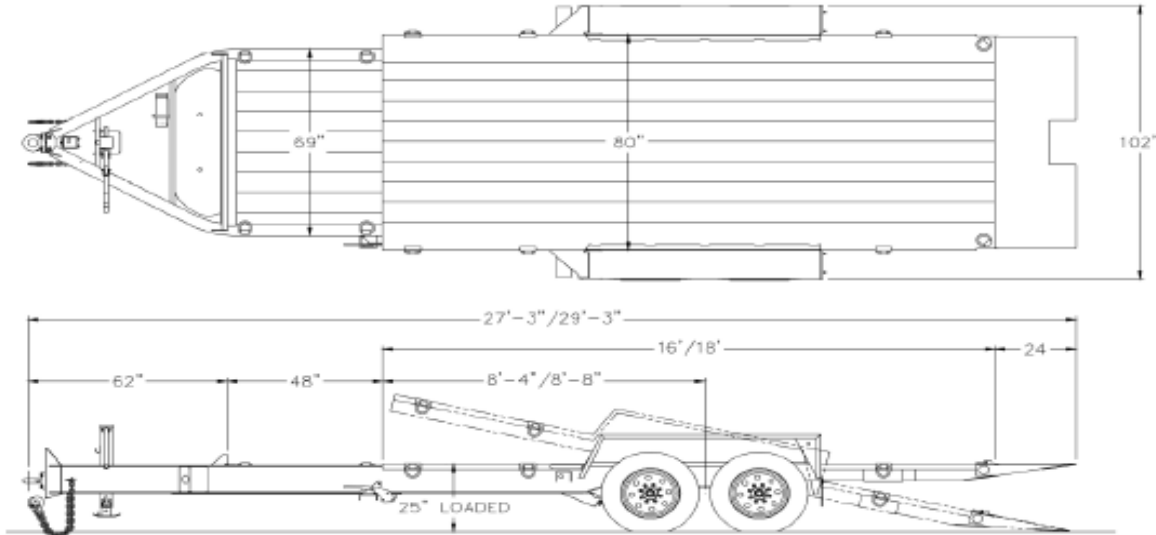

*All dimensions are nominal. Illustration may be shown with optional equipment.*

**Standard Features**

**Hitch/Tongue**

- Adjustable Height Hitch w/ Bolt-On Coupler
- 3" Pintle
- 7-Pole RV Plug
- One-Piece Cold-Formed I-Beam Frame Rails
- Integrated Storage Tray (Lockable Lid Optional)
- 12K Bolt-On, Side-Wind, Parking Jack
- Battery Break-Away Kit w/ Tow Charger & Test Light
- Safety Chains w/ Hooks

**Frame/Deck**

- 80" Load Width
- 25" Deck Height (Fully Loaded)
- 4' Stationary Deck
- Tilt Deck Cushion Cylinder
- Dual-Point, Single Lever Deck Lock
- 10" I-Beam Main Frame
- 3" Channel Crossmembers
- 2" Nominal White Oak Deck
- "D"ring Tie-Downs - (6) Per Side
- 12 Gauge One-Piece Formed Fender / Panel

**Tail/Approach**

- 24" Knife Edge Approach Plate (In addition to 16' or 18' deck length)
- 16' Tilt Deck Load Angle 13°
- 18' Tilt Deck Load Angle 12°

**Axles/Suspension**

- Rubber-Ride Torsion Suspension Axles
- (2) 10,000 lb. Axles (4 Wheels)
- Tires - 235/75R17.5 Load Range "J", 18-Ply
- 17.5" Wheels, 8-Bolt
- Electric Brakes
- Oil Bath Hubs
- 34" Axle Spacing

**Lights/Wiring**

- Rubber Grommet Mounted LED Lights
- Sealed Modular Wiring Harness

**Standard Features**

- Limited Lifetime Frame Warranty - 10 years
- One-Year Full Warranty
- 10 Year Suspension Warranty
- Weatherproof Registration Holder
- Two-Component Polyurethane Primer & Paint
- Trailer Color: Equipment Black

**CHANGES TO STANDARD FEATURES & ADDED OPTIONS:**

18' Tilt Deck w/ 24" Non-Load Bearing Diamond Plate Approach (Total Tilting Deck of 20')

4' Stationary Deck

3" Pintle Ring

DOT Inspection

<b>SELL PRICE PER UNIT / FOB ZIEGLER:</b>	<b>\$21,550.00</b>
<b>FET (Federal Excise Tax):</b>	<b>NA</b>
<b>SELL PRICE w/ FET:</b>	<b>\$21,550.00</b>
<b>TRADE VALUE:</b>	<b>\$0.00</b>
<b>SALE PRICE PLUS FET LESS TRADE:</b>	<b>\$21,550.00</b>
<b>MINNESOTA MOTOR VEHICLE TAX @ 6.875%:</b>	<b>\$1,507.34</b>
<b>FREIGHT:</b>	<b>\$375.00</b>
<b>DOT INSPECTION:</b>	<b>\$160.00</b>
<b>TOTAL DUE</b> (Includes Freight to nearest Ziegler location & DOT Inspection!):	<b>\$23,592.34</b>

**IMPORTANT! PRICING DOES NOT INCLUDE!**

License Fees, Registration Fees, Title Transfer Fees, Transit Excise Tax, Sales Tax, Federal, State or Local Taxes unless noted!

Respectfully Submitted, Corey Knuppel  
Ziegler, Inc.

ACCEPTED BY THE CITY OF WACONIA

\_\_\_\_\_  
TIM LITFIN, MAYOR  
APRIL 6, 2026

**Prepared For**

CITY OF WACONIA PUBLIC WORKS  
 310 E 10TH ST  
 WACONIA, MN 553879509

**Prepared By**

PAUL MURPHY  
 Kibble Equipment  
 1051 Old Hwy 169 Blvd  
 Belle Plaine, MN 56011  
 9524060701  
 paul.murphy@kibbleeq.com

**Quote Id** 1615613

**Creation Date** 11-Feb-2026

**Expiration Date** 20-Apr-2026

### Quote Summary

Equipment Summary	Selling Price	QTY In Group	Extended
GATOR™ XUV 845M HVAC (Model Year 2026)	\$30,226.57	1	\$30,226.57
John Deere 7-Pin Connector, installed	\$500.00	1	\$500.00
<b>Equipment Total</b>			<b>\$30,726.57</b>

**Quote Summary**

Total Selling Price	\$30,726.57
Total Taxable Equipment Fees	\$0.00
<b>Sub-total</b>	<b>\$30,726.57</b>
*Total Non-Taxable Equipment Fees	\$0.00
Rental Applied	\$0.00
<b>Total Amount Due</b>	<b>\$30,726.57</b>
Down Payment	\$0.00
<b>Balance Due</b>	<b>\$30,726.57</b>

Salesperson : X \_\_\_\_\_

Accepted By : X \_\_\_\_\_

## Selling Equipment

Quote # 1615613  
 Customer CITY OF WACONIA PUBLIC WORKS

### GATOR™ XUV 845M HVAC (Model Year 2026)

QTY In Group : 1

Equipment Notes Selling Price  
 Hours --- \$30,226.57  
 Serial Number ---  
 Stock Number ---  
 PUK Parent Serial #

### Equipment Summary

Code	Description	Qty	Adjusted Selling Price
8816M	GATOR™ XUV 845M HVAC (Model Year 2026)	1	\$29,999.00

### Base / Options

Code	Description	Qty	Adjusted Selling Price
001F	US 49 State	1	\$0.00
0505	Build To Order	1	\$0.00
182A	Less AutoTrac™/GreenStar™ Harness	1	\$0.00
183B	Less JDLink™ Hardware	1	\$0.00
1950	Less Application	1	\$0.00
2500	Green and Yellow	1	\$0.00
1062	27" Predator Heavy-Duty all-terrain radial tires on 14" Yellow Alloy Wheels	1	\$650.00
4022	Full Door with Side Mirrors	1	\$0.00
4063	HVAC Cab with Radio	1	\$1,300.00
2350	Park Position in Transmission	1	\$0.00
5007	Premium Protection Package	1	\$1,200.00
5110	Premium Comfort and Convenience Package	1	\$1,600.00

**Total Base / Options \$34,749.00**

### Technology Options

Code	Description	Qty	Adjusted Selling Price
1880	Less Receiver	1	\$0.00
1900	Less Display	1	\$0.00

**Total Technology Options \$0.00**

**Dealer Attachments**

Code	Description	Qty	Adjusted Selling Price
BM26477	Rearview mirror Serial Number: --- Stock Number: ---	1	\$219.93
BUC11349	Backup alarm Serial Number: --- Stock Number: ---	1	\$122.50
<b>Total Dealer Attachments</b>			<b>\$342.43</b>

**Customer Discounts**

Description	Discount Amount
<b>Total Discounts</b>	<b>(\$4,864.86)</b>
<b>Selling Price Subtotal</b>	<b>\$30,226.57</b>
<b>Total Selling Price</b>	<b>\$30,226.57</b>

**John Deere 7-Pin Connector, installed**

QTY In Group : 1

Equipment Notes

Selling Price

Hours ---

\$500.00

Serial Number

Stock Number ---

PUK Parent Serial # ---

**Equipment Summary**

Code	Description	Qty	Adjusted Selling Price
1	John Deere 7-Pin Connector, installed	1	\$500.00
<b>Total Base / Options</b>			<b>\$500.00</b>
<b>Selling Price Subtotal</b>			<b>\$500.00</b>
<b>Total Selling Price</b>			<b>\$500.00</b>



**REQUEST FOR CITY COUNCIL ACTION**

<b>Meeting Date:</b> April 6, 2026	
<b>Item Name:</b> 8.8. Lodging Tax Fund Request - Waconia Convention & Visitors Bureau (CVB)	
<b>Originating Dept:</b> Finance	
<b>Presented By:</b> Amanda Ortloff	
<b>Previous Council Action:</b> None	
<b>Item Type:</b>	Consent
<p><b>RECOMMENDATIONS/COUNCIL ACTION/MOTION REQUESTED:</b> Motion to Approve Request for Lodging Tax Reimbursement from the Waconia CVB for Expenditures Incurred January through March 2026</p> <p><b>EXPLANATION OF AGENDA ITEM:</b></p> <p>The Waconia Chamber CVB has requested a lodging tax reimbursement for expenditures incurred from January through March 2026. Staff reviewed the request for reimbursement and supporting invoices as approved by the CVB. Lodging tax funds are currently available for payment of these expenditures.</p> <p>Staff recommends approval of the request in the amount of \$10,920.</p> <p><b>ATTACHMENTS:</b> None</p>	
<b>FINANCIAL IMPLICATIONS:</b>	<b>ADVISORY BOARD RECOMMENDATIONS:</b>
Funding Sources & Uses: Lodging Tax Fund	Planning Commission:
Budget Information:	Park Board:
<input checked="" type="checkbox"/> Budgeted	Personnel Committee:
<input type="checkbox"/> Non-Budgeted	Other: More sample text.
<input type="checkbox"/> Amendment Required	



**REQUEST FOR CITY COUNCIL ACTION**

<b>Meeting Date:</b> April 6, 2026	
<b>Item Name:</b> 8.9. Cash Donations for Fire Safety and Prevention Efforts and Approving Pass Thru to the National Fire Safety Council	
<b>Originating Dept:</b> Finance	
<b>Presented By:</b> Nicole Meyer	
<b>Previous Council Action:</b> None	
<b>Item Type:</b>	Consent
<b>RECOMMENDATIONS/COUNCIL ACTION/MOTION REQUESTED:</b> Adopt Resolution No. 2026-094 Accepting Cash Donations Fire Safety and Prevention Efforts	
<b>EXPLANATION OF AGENDA ITEM:</b>	
<p>The City of Waconia received the following cash donations for fire safety and prevention efforts. The following parties donated to the City's Fire Department for these efforts:</p> <p>Ronald Miller - \$105          Barbara Radde - \$70          Security Bank &amp; Trust - \$500          Yetzer Home Store - \$70</p> <p>With the Council's acceptance of this donation, Staff will recognize the donation as revenue in the Fire Department's 2026 budget. The City works with the National Fire Safety Council for fire prevention materials and information. The donation received will be passed on to them so they can assist the department in future efforts.</p>	
<b>ATTACHMENTS:</b>	
1. Resolution No. 2026-094 Cash Donations Fire Safety and Prevention	
<b>FINANCIAL IMPLICATIONS:</b>	<b>ADVISORY BOARD RECOMMENDATIONS:</b>
Funding Sources & Uses: General Fund - Fire	Planning Commission:
Budget Information:	Park Board:
_____ Budgeted	Personnel Committee:
_____ Non-Budgeted	Other:
_____ Amendment Required	

**CITY OF WACONIA  
RESOLUTION NO. 2026-094**

**RESOLUTION ACCEPTING CASH DONATIONS FOR  
FIRE SAFETY AND PREVENTION EFFORTS AND  
APPROVING PASS THRU TO THE NATIONAL FIRE SAFETY COUNCIL**

**WHEREAS**, the City of Waconia is generally authorized to accept contributions of real and personal property pursuant to Minnesota Statutes Sections 412.21 and 465.03 for the benefit of its citizens and is specifically authorized to accept gifts and requests for the benefit of facilities, services and the development of programs to benefit residents pursuant to Minnesota Statutes Section 471.17; and

**WHEREAS**, the following persons and/or entities have offered to contribute the items set forth below to the City:

<u>Name of Donor</u>	<u>Item</u>	<u>Value</u>
Ronald Miller	Cash Donation for Fire Safety/Prevention	\$105
Barbara Radde	Cash Donation for Fire Safety/Prevention	\$ 70
Security Bank & Trust	Cash Donation for Fire Safety/Prevention	\$500
Yetzer Home Store	Cash Donation for Fire Safety/Prevention	\$ 70

**WHEREAS**, these donations have been contributed for the benefit of residents within the City's corporate limits either alone or in cooperation with others, as allowed by law; and

**WHEREAS**, donations will be passed thru to the National Fire Safety Council for their efforts in providing the City with fire safety and prevention materials; and

**WHEREAS**, the City Council hereby finds that it is appropriate to accept the contributions offered.

**NOW, THEREFORE, BE IT RESOLVED BY THE CITY COUNCIL OF WACONIA, MINNESOTA, AS FOLLOWS:**

1. The contribution described above is hereby accepted and acknowledged with gratitude.
2. Said contribution shall be used for the designated purposes.
3. That the Finance Director is hereby directed to issue receipts to the donor acknowledging the City's receipt of the donor's contribution.

Adopted by the City Council of the City of Waconia this 6<sup>th</sup> day of April 2026.

\_\_\_\_\_  
Tim Litfin, Mayor

ATTEST: \_\_\_\_\_  
Jackie Schulze, Assistant City Administrator



**REQUEST FOR CITY COUNCIL ACTION**

<b>Meeting Date:</b> April 6, 2026	
<b>Item Name:</b> 8.10. Donation and Approve Pass Thru Recommendation - Waconia Fire Relief Association	
<b>Originating Dept:</b> Finance	
<b>Presented By:</b> Nicole Meyer	
<b>Previous Council Action:</b> None	
<b>Item Type:</b>	Consent
<p><b>RECOMMENDATIONS/COUNCIL ACTION/MOTION REQUESTED:</b> Adopt Resolution No. 2026-095 Accepting Donation and Approving Pass Through Recommendation from Waconia Fire Relief Association</p> <p><b>EXPLANATION OF AGENDA ITEM:</b></p> <p>The City received a donation from the Waconia Fire Department Gambling Board totaling \$3,000. The gambling board approved this donation as a pass-through for the following purposes:</p> <ul style="list-style-type: none"> <li>• \$3,000 – Public Services Open House Event Food Tickets</li> </ul> <p>With the Council’s acceptance of the donation and recommended purpose for pass through by the gambling board, City staff will recognize the donation revenue and off-setting expenditures in the Water Utility Fund budget (601).</p> <p><b>ATTACHMENTS:</b></p> <p>1. Resolution No. 2026-095 Fire Relief Association</p>	
<b>FINANCIAL IMPLICATIONS:</b>	<b>ADVISORY BOARD RECOMMENDATIONS:</b>
Funding Sources & Uses: Water Utility Fund (601)	Planning Commission:
Budget Information:	Park Board:
_____ Budgeted	Personnel Committee:
X _____ Non-Budgeted	Other:
_____ Amendment Required	

**CITY OF WACONIA  
RESOLUTION NO. 2026-095  
RESOLUTION ACCEPTING DONATION AND PASS THRU  
RECOMMENDATION FROM  
WACONIA FIRE RELIEF ASSOCIATION**

**WHEREAS**, the City of Waconia is generally authorized to accept contributions of real and personal property pursuant to Minnesota Statutes Sections 412.21 and 465.03 for the benefit of its citizens and is specifically authorized to accept gifts and requests for the benefit of recreational facilities, services and the development of programs to benefit residents pursuant to Minnesota Statutes Section 471.17; and

**WHEREAS**, the following persons and/or entities have offered to contribute the items set forth below to the City:

<u>Name of Donor</u>	<u>Item</u>	<u>Value</u>	<u>Department/Fund</u>
Waconia Fire Gambling Board	Check	\$3,000	Water Utility Fund

**WHEREAS**, these donations have been contributed for the benefit of residents within the City's corporate limits either alone or in cooperation with others, as allowed by law; and

**WHEREAS**, the City Council hereby finds that it is appropriate to accept the contributions offered.

**WHEREAS**, the Waconia Fire Department Gambling Board wishes to enhance the donation by passing the funds thru for the following purpose:

- \$3,000 – Public Services Open House Event Food Tickets

**NOW, THEREFORE, BE IT RESOLVED BY THE CITY COUNCIL OF WACONIA, MINNESOTA, AS FOLLOWS:**

1. The contribution described above is hereby accepted and acknowledged with gratitude.
2. Said contribution shall be deposited to the appropriate funds and used for the designated purposes.
3. That the Finance Director is hereby directed to issue receipts to the donor acknowledging the City's receipt of the donor's contribution.

Adopted by the City Council of the City of Waconia this 6<sup>th</sup> day of April 2026.

\_\_\_\_\_  
Tim Litfin, Mayor

ATTEST: \_\_\_\_\_  
Jackie Schulze, Assistant City Administrator



**REQUEST FOR CITY COUNCIL ACTION**

<b>Meeting Date:</b>	April 6, 2026
<b>Item Name:</b>	8.11. Sale or Disposal of Surplus Equipment
<b>Originating Dept:</b>	Finance
<b>Presented By:</b>	Nicole Meyer
<b>Previous Council Action:</b> None	
<b>Item Type:</b>	Consent

**RECOMMENDATIONS/COUNCIL ACTION/MOTION REQUESTED:** Adopt Resolution No. 2026-096 Approving Surplus Equipment and Sale

**EXPLANATION OF AGENDA ITEM:**

City staff have reviewed inventory and items in storage at the Public Services Facility. Staff are requesting this equipment be deemed surplus equipment and be sold or properly disposed of as the equipment cannot be used in the City's current operations.

- 3 Large File Cabinets
- Dayton 150,000 BTU Heater S/N 3100938
- Old Boat Anchors
- Dewalt Circular Saw
- Tree Watering Bags
- Bunker Cover (used to make outdoor ice rink)
- Stihl Power Tool (Asset #9024 — no longer runs)
- Small Dewalt Power Hand Towels (over 15 years old and no batteries to use)
- Asphalt Cutter for a Bucket
- Stihl Power Tool (Asset #6006 - no longer runs)
- Miscellaneous nails, chicken wire, and barbwire

City staff will review the equipment with the various surplus vendors, including the State of Minnesota auction site to determine the best place to list the equipment. Staff will list the equipment and supplies at the lowest price the City will accept, and the equipment will be sold to the highest bidder. Funds from the sale will be recognized in the General Fund - Streets (101) as reimbursement revenue.

**ATTACHMENTS:**

1. Resolution No. 2026-096 Surplus Equipment and Sale

<b>FINANCIAL IMPLICATIONS:</b>	<b>ADVISORY BOARD RECOMMENDATIONS:</b>
Funding Sources & Uses: General Fund - Streets (101)	Planning Commission:
Budget Information:	Park Board:
_____ Budgeted	Personnel Committee:
_____ Non-Budgeted	Other:

<u>          </u> Amendment Required	
--------------------------------------	--

**CITY OF WACONIA  
RESOLUTION NO. 2026-096**

**RESOLUTION APPROVING SURPLUS EQUIPMENT AND SALE**

**WHEREAS**, Public Services staff have identified equipment in storage that is no longer used in the department’s operation; and

**WHEREAS**, the list of surplus items includes the following:

- 3 Large File Cabinets
- Dayton 150,000 BTU Heater S/N 3100938
- Old Boat Anchors
- Dewalt Circular Saw
- Tree Watering Bags
- Bunker Cover (used to make outdoor ice rink)
- Stihl Power Tool (Asset #9024 - no longer runs)
- Small Dewalt Power Hand Towels (over 15 years old and no batteries to use)
- Asphalt Cutter for a Bucket
- Stihl Power Tool (Asset #6006 - no longer runs)
- Miscellaneous nails, chicken wire, and barbwire

**WHEREAS**, funds received for the equipment with saleable value will be recognized in the General Fund – Streets department (101) as reimbursement revenue; and

**WHEREAS**, equipment that cannot be sold will be properly disposed of by City staff.

**NOW, THEREFORE, BE IT RESOLVED** the City Council of the City of Waconia hereby declares the equipment listed as surplus and authorizes its sale or disposal as determined by City staff.

Adopted by the City Council of the City of Waconia this 6<sup>th</sup> day of April 2026.

\_\_\_\_\_  
Tim Litfin, Mayor

ATTEST: \_\_\_\_\_  
Jackie Schulze, Assistant City Administrator



**REQUEST FOR CITY COUNCIL ACTION**

<b>Meeting Date:</b> April 6, 2026	
<b>Item Name:</b> 8.12. Waconia Works Loan, 125 1st Street West, Bakery Off Main	
<b>Originating Dept:</b> Finance	
<b>Presented By:</b> Nicole Meyer	
<b>Previous Council Action:</b> None	
<b>Item Type:</b>	Consent
<b>RECOMMENDATIONS/COUNCIL ACTION/MOTION REQUESTED:</b> Adopt Resolution No. 2026-097 Approving Waconia Works Loan for Bakery Off Main Relocating at 125 1st Street West	
<b>EXPLANATION OF AGENDA ITEM:</b>	
<p>City staff have received an application for the Waconia Works Loan program from Bakery Off Main. Bakery Off Main is the relocation of Bakery On Main. The owners, Greg and Bria James are relocating and expanding the bakery business from 136 Main Street West to 125 1st Street West. The move and expansion will require the purchase of new equipment; this includes a vent less oven, bakery cases, refrigerator units, industrial coffee/latte machine, stand-up mixer, along with some plumbing and electrical work. The owners have requested a five-year loan totaling \$40,000 to purchase these items. The total project costs for the start-up are estimated to be around \$50,000. The owner plans to make a cash contribution to the project of \$10,000. The owner has provided the application along with supporting documents requested under the program.</p> <p>With the Council's approval, staff will work to get documents drawn up and signed by the borrowers. Under the program, the borrowers will be required to sign a promissory note, loan agreement, and automatic payment agreement. The total amount requested will be amortized over a five-year period with a 2.0% interest rate. Monthly payments under this program are requested to be paid to the City with electronic funds and are expected to start on June 1, 2026. The total estimated monthly payment will be \$701.11.</p>	
<b>ATTACHMENTS:</b>	
1. Resolution No. 2026-097 Waconia Works Loan Bakery Off Main	
<b>FINANCIAL IMPLICATIONS:</b>	<b>ADVISORY BOARD RECOMMENDATIONS:</b>
Funding Sources & Uses: Revolving Loan Fund (202)	Planning Commission:
Budget Information:	Park Board:
_____ Budgeted	Personnel Committee:
_____ Non-Budgeted	Other:
_____ Amendment Required	

**CITY OF WACONIA  
RESOLUTION 2026-097**

**RESOLUTION APPROVING WACONIA WORKS LOAN FOR  
BAKERY OFF MAIN  
125 1<sup>ST</sup> STREET WEST**

**WHEREAS**, the City has approved three economic development programs to support the downtown commercial core, commercial and industrial sectors, and small business start-ups; and

**WHEREAS**, the City has received a Waconia Works Loan application from Greg and Bria James, the owners of a current business known as Bakery On Main which was previously located at 136 Main Street West; and

**WHEREAS**, proposed project expenses include relocation and expansion expenses for new equipment; this including a vent less oven, bakery cases, refrigeration units, industrial coffee/latte machine, stand-up mixer along with plumbing and electrical work at the relocation site; and

**WHEREAS**, the purpose of the loan is consistent with the goals of the Waconia Works Loan and Economic Development Programs.

**NOW, THEREFORE, BE IT RESOLVED** that the City Council of the City of Waconia approves the 5-year, \$40,000 Waconia Works Loan for Bakery Off Main located at 125 1<sup>st</sup> Street West.

Adopted by the Waconia City Council this 6<sup>th</sup> day of April 2026.

\_\_\_\_\_  
Tim Litfin, Mayor

ATTEST: \_\_\_\_\_  
Jackie Schulze, Assistant City Administrator



**REQUEST FOR CITY COUNCIL ACTION**

<b>Meeting Date:</b> April 6, 2026	
<b>Item Name:</b> 9.1. Special Event Permit - Farmers Market	
<b>Originating Dept:</b> Administration	
<b>Presented By:</b> Shane Fineran	
<b>Previous Council Action:</b> None	
<b>Item Type:</b>	Regular Session
<b>RECOMMENDATIONS/COUNCIL ACTION/MOTION REQUESTED:</b> Adopt Resolution No. 2026-098 approving the Special Event Permit for the Waconia Farmers Market	
<b>EXPLANATION OF AGENDA ITEM:</b>	
<p>Nicole Waldron of the Waconia Farmers Market has submitted a Special Event Permit which returns the weekly farmers market event to Lot 1 for the 2026 season. The market is scheduled to begin June 4 and end October 15 from 4:00 p.m. to 7:00 p.m. Set-up and clean-up will occur between 2:00 p.m. and 8:00 p.m.</p> <p>The organizers are requesting that the event be considered "City Sponsored" under the Special Event Permit policy, through the waiver of the \$350 permit application fee and the \$250 fee for encumbered stalls in a public parking lot. Organizers note that the fees waived will help support a Food Rescue Coordinator and SNAP Market Match programming.</p>	
<b>ATTACHMENTS:</b>	
<ol style="list-style-type: none"> <li>1. Resolution No. 2026-098 Special Event Permit Famers Market</li> <li>2. Request Letter and Site Map</li> <li>3. Farmers Market SEP 2026</li> </ol>	
<b>FINANCIAL IMPLICATIONS:</b>	<b>ADVISORY BOARD RECOMMENDATIONS:</b>
Funding Sources & Uses:	Planning Commission:
Budget Information:	Park Board:
_____ Budgeted	Personnel Committee:
_____ Non-Budgeted	Other:
_____ Amendment Required	

**CITY OF WACONIA  
RESOLUTION NO. 2026-098**

**RESOLUTION APPROVING THE SPECIAL EVENT PERMIT  
FOR WACONIA FARMERS MARKET**

**WHEREAS**, The Waconia Farmers Market have submitted a Special Event Permit for the use of city parking lot space for a weekly farmers market; and

**WHEREAS**, request closure and use of a portion of Lot 1 weekly on Thursday's from 2:00 p.m. to 8:00 p.m. June 4<sup>th</sup> through October 15<sup>th</sup>.; and

**WHEREAS**, the consideration of this event to be City sponsored under the Special Event Policy with waiver of the permit fee and parking impact fee of a total of \$600 and

**NOW, THEREFORE, BE IT RESOLVED** That the City Council of the City of Waconia hereby approves the Special Event Permit and designates this event a city supported event.

Adopted by the City Council of the City of Waconia this 6<sup>th</sup> day of April 2026.

\_\_\_\_\_  
Tim Litfin, Mayor

Attest: \_\_\_\_\_  
Jackie Schulze, Assistant City Administrator

**From:** [Nicole](#)  
**To:** [Shane Fineran](#)  
**Subject:** The Waconia Farmers Market  
**Date:** Monday, March 30, 2026 4:03:46 PM  
**Attachments:** [Special-Event-Permit-Application.pdf](#)

---

Administrator Fineran, Mr. Mayor and Councilmembers,

The Waconia Farmers Market was a huge success last year and we are excited to continue that momentum. I want to begin by thanking you for your partnership. This past year we were able to offer The Power of Produce Club allowing children to receive \$2 tokens to spend on fresh produce. The addition of this program has helped to attract many new vendors especially those offering fresh produce.

I believe that the summer market, as well as the city's Summer Music Series, will continue to grow making Thursday evenings in Waconia the highlight of summer. As we continue to foster that relationship, I would like to request that The Waconia Farmers Market becomes a city sponsored event and that the application and parking space fees be waived. The intention will be to use those funds to support additional programs including a Food Rescue Coordinator and SNAP Market Match programs.

The positive feedback from the residents and business community supports the decision to keep the location the same for the 2026 season. This year I would like to expand the footprint of the market to accommodate for growth and to improve safety of the shoppers. We again request permission to place signs for advertising on Wednesdays before and remove them Thursday evenings following the market. I would also be interested in exploring more permanent or summer-long advertising options that may be available. I appreciate your time and consideration.

Sincerely,

Nicole Waldron  
The Waconia Farmers Market

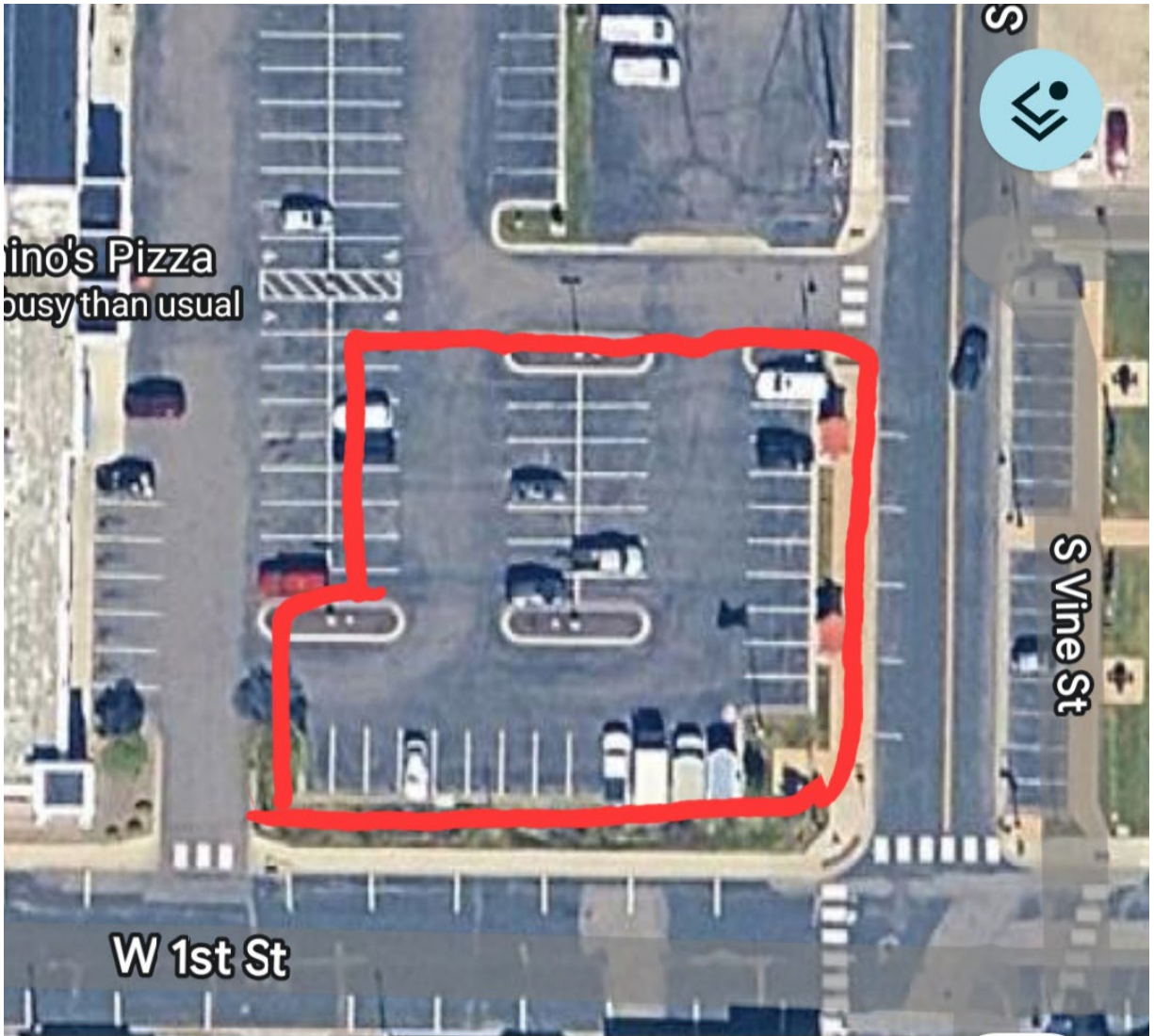

ino's Pizza  
busy than usual

W 1st St

S Vine St



---

**Special Event Permit**

**SECTION 1 – CONTACT INFORMATION**

**Applicant (person completing this form)**

Name: \_\_\_\_\_

Phone: \_\_\_\_\_

Email: \_\_\_\_\_

Role (Owner / Manager / Partner / Agent / Other): \_\_\_\_\_

**On-Site Contact (required during event)**

Name: \_\_\_\_\_

Phone: \_\_\_\_\_

Email: \_\_\_\_\_

**SECTION 2 – EVENT OVERVIEW**

Event Name: \_\_\_\_\_

Event Date(s): \_\_\_\_\_

Event Time: \_\_\_\_\_ to \_\_\_\_\_

Setup Start Time: \_\_\_\_\_ Cleanup End Time: \_\_\_\_\_

Event Location (address): \_\_\_\_\_

Is the event outdoors?  Yes  No

Is the event in a City park?  Yes  No

Estimated Attendance: \_\_\_\_\_

Are tickets sold?  Yes  No

If yes, admission price: \$ \_\_\_\_\_

Brief description of event activities/entertainment:

---

**SECTION 3 – CHECK ALL THAT APPLY**

Amplified sound (music, DJ, PA system)

Alcohol will be served

Street / sidewalk / public area closure

Tents or temporary structures

150+ attendees

(You will only complete the matching sections below.)

**SECTION 4 – FOOD, SAFETY & OPERATIONS (ALL EVENTS)**

Food & beverage plan (who is serving, permits if needed):

\_\_\_\_\_

Emergency / medical plan:

\_\_\_\_\_

Trash plan (bins, cleanup):

\_\_\_\_\_

Will portable toilets be provided?  Yes  No

If yes, provider & quantity: \_\_\_\_\_

**SECTION 5 – AMPLIFIED SOUND (ONLY IF APPLICABLE)**

No amplified sound

Sound under 85 decibels

Sound past 10:30 PM (waiver required)

Noise control plan: \_\_\_\_\_

**SECTION 6 – STREET / PUBLIC AREA CLOSURE (ONLY IF APPLICABLE)**

Closure requested?  Yes  No (Please provide traffic control and/or detour plan if checked “yes”)

Duration:  Under 15 minutes  15+ minutes

Streets/areas affected:

\_\_\_\_\_

Traffic control vendor: \_\_\_\_\_

Emergency vehicle access plan:

\_\_\_\_\_

**SECTION 7 – ALCOHOL SERVICE (ONLY IF APPLICABLE)**

Alcohol will be served?  Yes  No

Type of service (check all that apply):  Temporary liquor license (separate application required)

Licensed on-sale vendor(s)  Licensed caterer  Community festival designation

Alcohol provider(s): \_\_\_\_\_

Liquor liability insurance holder: \_\_\_\_\_

Alcohol service area & age-control plan:

\_\_\_\_\_

Will security officers be hired?  Yes  No

**SECTION 8 – TENTS / FIREWORKS (ONLY IF APPLICABLE)**

**Tents**

Tent provider: \_\_\_\_\_  
Tent size (sq. ft.): \_\_\_\_\_ (Permit required if over 400 sq. ft.)

**SECTION 9 – CERTIFICATION & SIGNATURE**

I certify that the information provided is accurate and that I will comply with all City of Waconia and State of Minnesota requirements.

Printed Name: \_\_\_\_\_

Signature: \_\_\_\_\_

Date: \_\_\_\_\_

**Submission Notes**

- Submit at least **60 days before** the event
- Permit fee: **\$350 (non-refundable) See below for additional rates (only if applicable)**
  - Special Event Parking Lot Stall \$1.00 Per stall/per event\$250 max per application
  - Special Event On Street Parking Stall \$3.00 Per stall/per event\$500 max per application
- Temporary liquor license deadline: **60 days before event**
- Certificate of Insurance listing City of Waconia as the Certificate Holder: **10 days before event**

**TENNESSEN WARNING:** In connection with your request for a license, the City has asked that you provide information about yourself which may be classified as private, confidential, nonpublic, or protected nonpublic under the Minnesota Government Data Practices Act. This means that this data is not ordinarily available to the general public. Accordingly, the City is required to inform you of the following:

1. The purpose and intended use of the information requested is to determine if you or an applicant affiliated with you is eligible for a license from the City of Waconia.
2. You are not legally obligated to supply the request information.
3. The known consequence of supplying the requested information is that the information or further investigation could disclose information which could cause the license application to be denied.
4. The known consequences of refusing to supply the requested information is that the application for a license cannot be processed.
5. A criminal charge, arrest, or conviction will not necessarily bar you from obtaining a license with the City, unless the conviction is related to the matter for which the license is sought, according to Minnesota Statute 364.03. However, failure to reveal the requested criminal information will be considered falsification of the application and may be used as grounds for the denial of the application.
6. Other governmental agencies necessary to process your application are authorized by law to receive the information provided.
7. The City is required by law to furnish some of this information to the Department of Labor and Industry and the Minnesota Commissioner of Revenue

Signature of Applicant: \_\_\_\_\_ Date: \_\_\_\_\_



**REQUEST FOR CITY COUNCIL ACTION**

<b>Meeting Date:</b>	April 6, 2026
<b>Item Name:</b>	9.2. Order Feasibility Report and Assessment Benefit Evaluation for 5th Street Reconstruction
<b>Originating Dept:</b>	Public Services
<b>Presented By:</b>	Jon Haukaas
<b>Previous Council Action:</b>	Resolution No. 2025-264 Accepting the 2025 Pavement Management Plan Update Resolution No. 2023-175 Authorizing City Engineer to Prepare Preliminary Design of Trunk Highway Five Phase II Corridor Improvements
<b>Item Type:</b>	Regular Session
<b>RECOMMENDATIONS/COUNCIL ACTION/MOTION REQUESTED:</b> Adopt Resolution No. 2026-099 Ordering a Feasibility Report and Assessment Benefit Evaluation for 5th Street Reconstruction	
<b>EXPLANATION OF AGENDA ITEM:</b>	
<p>This action would initiate a project to reconstruct a portion of 5th Street from Olive Street to Oak Street in coordination with work required for the Trunk Highway 5 project and include assessments of a portion of the cost to the adjacent benefiting parcels.</p> <p>The design of the Hwy 5 project necessitated the relocation of the watermain to outside the highway corridor. The preferred alignment was determined to be along 5th Street to the north. Parts of Elm Street and Pine Street will also be impacted by the highway construction for watermain connections, sanitary sewer reconstruction and storm sewer extensions. Because these relocations are required for highway construction, they are eligible for federal funding and may be paid for with grant funds. Grant funds may also be applied to a portion of the adjacent street and storm sewer improvements, typically limited to the equivalent cost of pavement patching associated with the work.</p> <p>These segments of local roadways are currently included in the City’s Pavement Management Plan and are planned to be reconstructed as part of various projects from 2029 through 2033. Due to the extent of the work and required patching, it is recommended to develop a project to fully reconstruct these roadways with the Highway project. To maintain fairness and consistency with other street reconstruction projects and funding, the project should include assessments of a portion of the cost to the adjacent benefiting parcels. This will require the City to follow the MN Statute Chapter 429 process. The process begins with the completion of a Feasibility Study and the holding of a Public Hearing. By authorizing the Feasibility Study in April and holding the Public Hearing in June, the timeline for this local project would line up with the larger Hwy 5 project. This allows for the projects to be bid together and for a portion of the local project work to be eligible to receive grant funding.</p> <p>In order to maximize eligible grant funds and to include upcoming planned street and utility reconstruction work as part of the Hwy 5 project, it is recommended to authorize a Feasibility</p>	

Study for portions of 5th Street, Elm Street, and Pine Street. Consistent with past local assessment projects, it is also recommended to initiate the benefit evaluation process upon completion of the Feasibility Study. The following tentative schedule outlines the necessary remaining significant steps for the Hwy 5 Phase 2 project if the local roadways are included. The later project steps will be combined with the 2027 Street Reconstruction Project Assessment process for efficiency.

1. April 2026 Authorize the Completion of a Feasibility Study for Local Project
2. May 2026 Complete Feasibility Study & Order Public Hearing
3. Spring 2026 Hwy 5 Right-of-Way Acquisitions Completed & Plans Approved by MnDOT
4. 2026 Continuation of Grant Funding Coordination & Frontage Rd Grant Pursuits
5. June 2026 Hold Public Hearing & Order Local Improvements
6. June 30, 2026 Deadline to Have Hwy 5 Authorized by the FHWA & MnDOT
7. Fall 2026 Advertising & Bidding
8. Winter 2026-27 Permitting
9. 2027-28 Construction

Staff recommends adoption of the Resolution in order to proceed with the project.

**ATTACHMENTS:**

1. Resolution No. 2026-099 Feasibility Study 5th Street Reconstruction
2. Hwy 5 Local Street Project

<b>FINANCIAL IMPLICATIONS:</b>	<b>ADVISORY BOARD RECOMMENDATIONS:</b>
Funding Sources & Uses:	Planning Commission:
Budget Information:	Park Board:
<input checked="" type="checkbox"/> Budgeted	Personnel Committee:
_____ Non-Budgeted	Other:
_____ Amendment Required	

**CITY OF WACONIA  
RESOLUTION NO. 2026-099  
RESOLUTION ORDERING PREPARATION OF FEASIBILITY STUDY &  
ASSESSMENT BENEFIT EVALUATION FOR  
THE HWY 5 AREA RECONSTRUCTION PROJECT**

**WHEREAS**, it is proposed to improve streets and utilities in the downtown area and to assess the benefiting properties for all or a portion of the cost of the improvements, pursuant to Minnesota Statutes, Chapter 429. The proposed project area includes the following locations:

- Fifth Street W from Olive Street to Elm Street
- Fifth Street E from Elm Street Orange Street
- Elm Street S from Hwy 5 to Fifth Street
- Pine Street S from Hwy 5 to Fifth Street

**NOW THEREFORE, BE IT RESOLVED** by the City Council of the City of Waconia, Minnesota,

1. That the proposed improvement, called the Hwy 5 Area Reconstruction Project, be referred for study and that the City Engineer is instructed to report to the council with all convenient speed advising the council in a preliminary way as to whether the proposed improvement is necessary, cost-effective, and feasible; whether it should best be made as proposed or in connection with some other improvement; the estimated cost of the improvement as recommended; and a description of the methodology used to calculate individual assessments for affected parcels.
2. That the proposed improvement also be referred for An Assessment Benefit Evaluation and that the City Attorney initiate and obtain a third-party benefit analysis after the completion of a Feasibility Study.

Adopted by the City Council of the City of Waconia this 6<sup>th</sup> day of April 2026.

\_\_\_\_\_  
Tim Litfin, Mayor

Attest: \_\_\_\_\_  
Jackie Schulze, Assistant City Administrator



Real People. Real Solutions.

2638 Shadow Lane  
Suite 200  
Chaska, MN 55318-1172

Ph: (952) 448-8838  
Fax: (952) 448-8805  
Bolton-Menk.com

March 23, 2026

City of Waconia  
Attn: Jon Haukaas  
310 10<sup>th</sup> Street East  
Waconia, MN 55387

**RE: Hwy 5 Phase 2 Improvements  
Local Project Addition**

Dear Mr. Haukaas,

Final design items are nearing completion for the Hwy 5 Phase 2 Improvement Project. The location of this next planned phase of work on Hwy 5 is from Hwy 284 / Olive Street to CSAH 59 as shown in the graphic below.

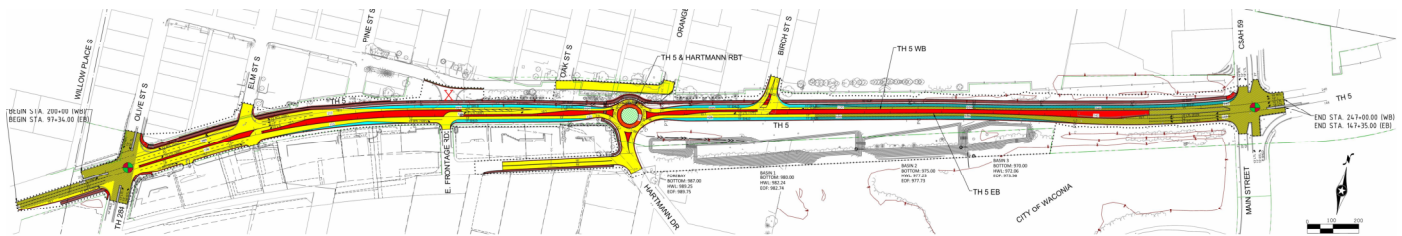

Steps Completed To Date:

The following significant steps have thus far been completed:

1. 2015-16 Hwy 5 Phase 1 Project Constructed
2. 2020-22 Hwy 5 Phase 2 Project Layouts Developed & Discussed with City Council, City Staff, Carver County, & MnDOT
3. Sep. 2022 Topographical Survey, Geotechnical, & Preliminary Design Work Authorized
4. 2022-25 Grant Funds Pursued (\$7 Mil Met Council Regional Solicitation & \$5 Mil Transportation Economic Development Successful) (State Legislative Funding, Federal Community Project Funding, & Carver County Local Option Sales Tax Pending)
5. Mar. 2023 Right-of-Way Acquisition Process Approved & Initiated
6. July 2023 Preliminary Design & Level 2 Layout Preparation Authorized

7. Aug. 2024 Public Open House No. 1 Held
8. Dec. 2024 Business Owner Meeting Held
9. Jan. 2025 Public Open House No. 2 Held
10. Mar. 2025 Level 2 Layout Submitted to MnDOT
11. Dec. 2025 Environmental Documentation Submitted
12. Mar. 2026 Public Open House No. 3 Held

Local Street & Utility Reconstruction:

The current design of the Hwy 5 project includes watermain relocation along the north side of the Hwy 5 corridor. The watermain located on 5<sup>th</sup> Street between Oak Street and Orange Street requires relocation due to the location of the proposed roundabout. The watermain located along Hwy 5 from Olive Street to Pine Street requires relocation to 5<sup>th</sup> Street to get it out of the Hwy 5 right-of-way. Due to these relocations being necessary for the construction of the highway, they are federally eligible items and can be paid with grant funds. Due to the extent of this work, it is recommended to also reconstruct the sanitary sewer on Elm Street and Pine Street, replace and expand the storm sewer system, and fully reconstruct the local roadways to the north of Hwy 5 that are highlighted in the figure below. Due to the watermain work, grant funds may also be able to be used for a portion of the street and storm sewer items that are located adjacent to the watermain. These segments of local roadways are currently included in the City's Pavement Management Plan and are planned to be reconstructed as part of various projects from 2029 through 2033.

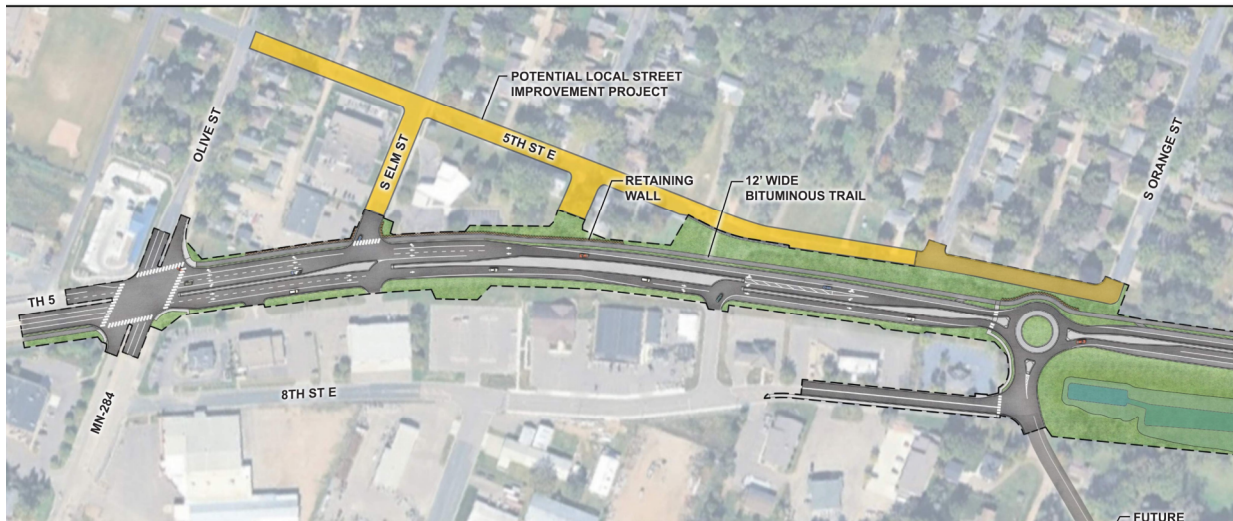

In order to assess the added local project items, the MN Statute Chapter 429 process will need to be followed. This requires the completion of a Feasibility Study and the holding of a Public Hearing. If the Feasibility Study was authorized in April and the Public Hearing was held in June, the timeline for this local project would line up with the larger Hwy 5 project. This would allow

for the projects to be bid together and for a portion of the local project work be eligible to receive grant funding.

**Recommendations & Schedule:**

In order to maximize eligible grant funds and to include upcoming planned street and utility reconstruction work as part of the Hwy 5 project, it is recommended to authorize a Feasibility Study for portions of 5<sup>th</sup> Street, Elm Street, and Pine Street. Consistent with past local assessment projects, it is also recommended to initiate the benefit evaluation process upon completion of the Feasibility Study. The following tentative schedule outlines the necessary remaining significant steps for the Hwy 5 Phase 2 project if the local roadways are included.

1. April 2026 Authorize the Completion of a Feasibility Study for Local Project
2. May 2026 Complete Feasibility Study & Order Public Hearing
3. Spring 2026 Hwy 5 Right-of-Way Acquisitions Completed & Plans Approved by MnDOT
4. 2026 Continuation of Grant Funding Coordination & Frontage Rd Grant Pursuits
5. June 2026 Hold Public Hearing & Order Local Improvements
6. June 30, 2026 Deadline to Have Hwy 5 Authorized by the FHWA & MnDOT
7. Fall 2026 Advertising & Bidding
8. Winter 2026-27 Permitting
9. 2027-28 Construction

Please note if additional grant funds are able to be obtained, the project scope may be further expanded to include the proposed frontage road to the south of Hwy 5 from Hartmann Drive to CSAH 59 / Main Street.

I am available to discuss this letter and this proposed project at your convenience.

Sincerely,

**Bolton & Menk, Inc.**

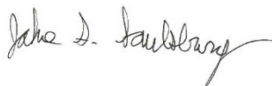

**Jake Saulsbury, P.E.**

Cc: Dan Lonnes, Bolton & Menk



## REQUEST FOR CITY COUNCIL ACTION

<b>Meeting Date:</b>	April 6, 2026
<b>Item Name:</b>	9.3. Authorize Feasibility Study for a Public Services Office Expansion
<b>Originating Dept:</b>	Public Services
<b>Presented By:</b>	Jon Haukaas
<b>Previous Council Action:</b>	Resolution No. 2023-058 Approve of Oertel Architects Proposal of Fee and Scope for Public Services Study
<b>Item Type:</b>	Regular Session
<b>RECOMMENDATIONS/COUNCIL ACTION/MOTION REQUESTED:</b> Adopt Resolution 2026-100 Authorizing Feasibility Study for Public Services Office Expansion project	
<b>EXPLANATION OF AGENDA ITEM:</b>	
<p>A space needs study for the Public Services campus was conducted in 2023 identifying two major needs of the department as Waconia continues to grow and increase its need for personnel to provide desired levels of service. This study showed the primary needs were in the areas of office space, crew locker rooms, meeting space, and equipment storage. A phased expansion approach included significantly expanding the footprint with new buildings at the existing location, or a complete relocation of the Public Services campus. The estimated cost for the initial phases has been included in the Capital Improvement Planning budget at \$20,000,000.</p> <p>The advancement of the Water Treatment Plant No. 4 (WTP4) project and associated property purchase has provided an opportunity to reevaluate how to meet the immediate future needs of the department. Staff met with the original Study provider, Oertel Architects, to look at new options. The result of these meetings led to the consideration of an alternative approach where the equipment needs could be met with a new Cold Storage building to be constructed with the WTP4 and the staff space needs met with an internal office mezzanine expansion.</p> <p>Oertel Architects provided a proposal that would deliver a 30% structural and architectural design of the office space along with a cost estimate, preliminary code analysis, and associated Mechanical/Electrical/Plumbing systems design narrative. The proposed cost is \$27,950 and would be funded from existing Engineering Services budget line items in the Streets, Parks, Water, Sewer, and Stormwater funds.</p> <p>Staff recommends approval of the Resolution and preparation of a Feasibility Study to better define the costs and scope of an office expansion to serve the needs of Public Services for the next decade.</p>	
<b>ATTACHMENTS:</b>	
<ol style="list-style-type: none"><li>1. Resolution No. 2026-100 PS Expansion Feasibility Study</li><li>2. PS Restorations Oertel Architects</li><li>3. Mezz Office markup 3-3-2026</li></ol>	

<b>FINANCIAL IMPLICATIONS:</b>	<b>ADVISORY BOARD RECOMMENDATIONS:</b>
Funding Sources & Uses:	Planning Commission:
Budget Information:	Park Board:
<input checked="" type="checkbox"/> Budgeted	Personnel Committee:
<input type="checkbox"/> Non-Budgeted	Other:
<input type="checkbox"/> Amendment Required	

**CITY OF WACONIA  
RESOLUTION NO. 2026-100  
RESOLUTION AUTHORIZING FEASIBILITY STUDY FOR  
PUBLIC SERVICES OFFICE EXPANSION PROJECT**

**WHEREAS**, the City of Waconia has identified the need for additional space at the Public Services facility to accommodate growing needs for staff to serve the community; and

**WHEREAS**, to better define and understand the space needs, design requirements, Building Code compliance, and building impacts; and

**WHEREAS**, to define the estimated costs, funding sources, and budget impacts, a feasibility study is recommended; and

**WHEREAS**, the city has been working with Oertel Architects, a firm specializing in Public Works space needs , who have provided a scope of work to complete this study at an estimate cost of \$27,950.00

**NOW THEREFORE, BE IT RESOLVED** That the City Council of the City of Waconia hereby authorizes the commencement of the Public Services Office Expansion Feasibility Study as proposed.

Adopted by the City Council of the City of Waconia this 6<sup>th</sup> day of April 2026.

\_\_\_\_\_  
Tim Litfin, Mayor

Attest: \_\_\_\_\_  
Jackie Schulze, Assistant City Administrator



# City of Waconia

## Public Services Renovation



**OA** OERTEL  
ARCHITECTS

Submitted by: Thomas Stromsodt, AIA, Vice President  
Oertel Architects, Ltd.  
1795 St. Clair Avenue, St. Paul, MN  
55105  
(651) 696-5186 x 314



March 18, 2026 (Revision No 1.)

## RE: Public Services Renovation

Jon,

Thank you for reaching out concerning moving to the next stage of renovation and expansion.

### PROJECT SCOPE ASSUMPTIONS:

The current concept includes the following scope items:

- Addition of an office mezzanine area within the existing vehicle storage area that will include space for (8) flexible office areas and a large training room able to accommodate approximately (30) people (tables and chairs) or (50) people (row seating)
- Renovation of existing computer/file area into addition men's locker room
- Maintain small vehicle parking below office mezzanine addition
- Egress and access pathways between existing office and new
- Existing cubicle area will become computer lab

The preliminary concept drawings are attached for reference.

### FEE SCOPE ASSUMPTIONS:

- There will be (4) meetings to review the proposed layout changes and present materials including one consultant team site visit to review existing conditions.
- The deliverables will include:
  - Progress drawings to 30% (Architectural and Structural)
  - Schematic Design Opinion of Cost/Budget Estimate
  - Mechanical/Electrical/Plumbing Design Narrative
  - Preliminary Code Analysis

PROPOSED FEE:

FEE ESTIMATE	fee	expenses	total
Schematic Design (Renovation)	\$27,700	\$250	\$27,950

Thank you again for the opportunity.  
Sincerely,

  
Thomas Stromsodt, AIA, Vice President

CONTACT

Oertel Architects, Ltd.  
Thomas Stromsodt, AIA, Principal  
1795 St. Clair Avenue | Saint Paul, MN 55105  
p: (651) 696-5186 ext. 314  
e: tstromsodt@oertelarchitects.com

SIGNATURE PAGE:

\_\_\_\_\_  
*Signature* TIM LITFIN, MAYOR  
*Name Printed*

\_\_\_\_\_  
*Title* TIM LITFIN, MAYOR  
*Date* APRIL 6, 2026

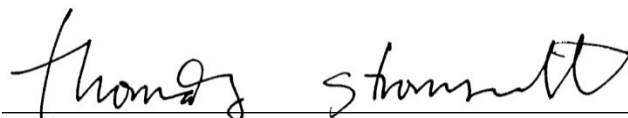
  
*Signature* Thomas Stromsodt  
*Name Printed*

\_\_\_\_\_  
*Title* Vice President, Oertel Architects  
*Date* March 18, 2026

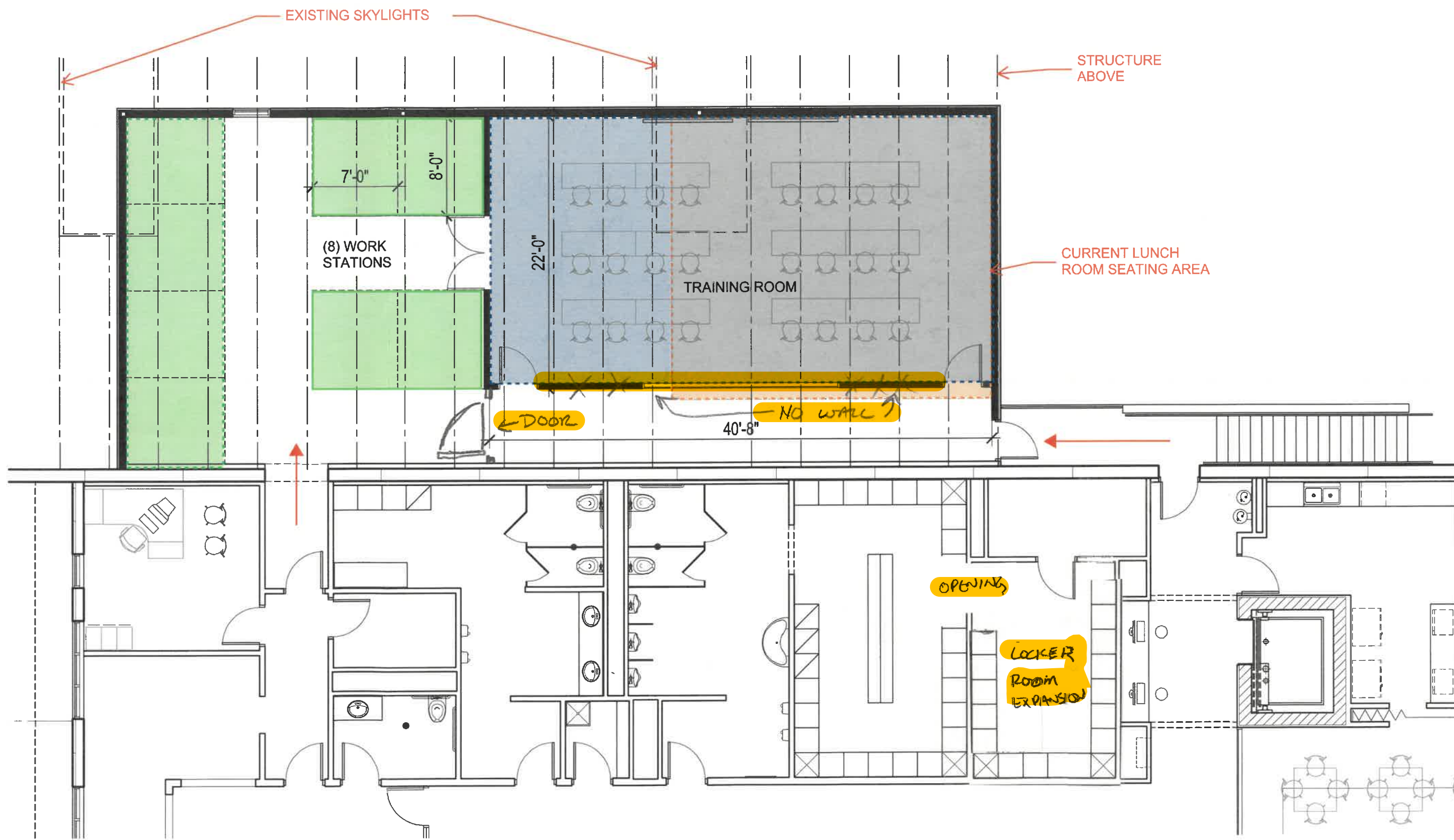

WACONIA PUBLIC WORKS - OFFICE  
 RENOVATION EXPANSION



**REQUEST FOR CITY COUNCIL ACTION**

<b>Meeting Date:</b>	April 6, 2026
<b>Item Name:</b>	9.4. Cold Storage Building Design - Professional Services Agreement Addendum
<b>Originating Dept:</b>	Public Services
<b>Presented By:</b>	Jon Haukaas
<b>Previous Council Action:</b>	Resolution No. 2025-157 Accept Professional Services Agreement for Water Treatment Plant No. 4
<b>Item Type:</b>	Regular Session
<p><b>RECOMMENDATIONS/COUNCIL ACTION/MOTION REQUESTED:</b> Adopt Resolution No. 2026-101 Authorizing Approval of Addendum to WTP 4 Design Professional Services Agreement with SEH, Inc.</p> <p><b>EXPLANATION OF AGENDA ITEM:</b></p> <p>A 2024 space needs study identified equipment storage as a major deficiency of the Public Services department. Public Services currently uses multiple locations for equipment storage, including the Old Public Works building near Highway 284 and County Road 10 and the old Fire Station at 1st Street and Walnut Street. Both of these locations share the need for significant upgrades and would most likely better serve the community as future redevelopment sites.</p> <p>The study provided several options to address this need, including a recommendation to construct additional space on the existing property or a complete new campus. The existing property is very constrained by the surrounding businesses, the adjacent Water Treatment Plant 3, Water Tower No. 3, and a major natural gas pipeline across the front of the site. In preparation for the eventual need to address this problem, the City CIP has included an initial budget of \$20,000,000 toward some type of expansion project. It is recognized that any such major expansion will be an expensive endeavor and that this amount of funding may not be sufficient for a full relocation or new buildings.</p> <p>The new Water Treatment Plant No. 4 (WTP4) project and property purchase has provided an additional opportunity to solve this issue. The project design included site work that would reserve space for a future 20,000 sf Cold Storage Building. The consultant for WTP4 estimated that such a building could be constructed at an estimated cost of \$4,000,000. The City requested an addendum proposal to include full architectural, structural, mechanical, electrical, and fire protection. SEH provided a proposal to provide this design for a contract amendment of \$118,750.</p> <p>Staff have reviewed the proposal and recommend acceptance as the most economical means to design the building and meet the future needs to provide the necessary level of service to our community.</p> <p><b>ATTACHMENTS:</b></p> <ol style="list-style-type: none"> <li>1. Resolution No. 2026-101 WTP4 Design Addendum</li> </ol>	

2. WTP4 Design Agreement Addendum

<b>FINANCIAL IMPLICATIONS:</b>	<b>ADVISORY BOARD RECOMMENDATIONS:</b>
Funding Sources & Uses: Budget Information: <input checked="" type="checkbox"/> Budgeted _____ Non-Budgeted _____ Amendment Required	Planning Commission: _____ Park Board: _____ Personnel Committee: _____ Other: _____

**CITY OF WACONIA  
RESOLUTION NO. 2026-101**

**RESOLUTION AUTHORIZING APPROVAL OF ADDENDUM  
TO WATER TREATMENT PLANT 4 DESIGN  
PROFESSIONAL SERVICES AGREEMENT WITH  
SHORT ELLIOT HENDRICKSON, INC.**

**WHEREAS**, one of the City’s Priorities is to “manage, maintain, and improve our current and future physical assets”; and

**WHEREAS**, the engineering firm of Short Elliot Hendrickson, Inc. (SEH) was selected through a competitive Request for Qualifications process to design the site and building improvements for the new Water Treatment Plant 4; and

**WHEREAS**, a 2024 space needs study identified equipment storage as a major deficiency of the Public Services department with a recommendation to construct additional space or a complete new campus the City CIP has included an initial budget of \$20,000,000 toward this type of expansion project; and

**WHEREAS**, the new Water Treatment Plant property has space to include a new Cold Storage Building that would serve this need at an estimated cost of \$4,000,000; and

**WHEREAS**, the City requested an addendum proposal from SEH to design a 20,000 sf Cold Storage Building to meet the City’s future needs to include full architectural, structural, mechanical, electrical, and fire protection design for a contract amendment of \$118,750.00; and

**WHEREAS**, staff have reviewed the proposal and recommend acceptance as the most economical means to design the building an meet the future needs to provide the necessary level of service to our community.

**NOW, THEREFORE, BE IT RESOLVED** That the City Council of the City of Waconia hereby authorizes approval of addendum to the Water Treatment Plant 4 Design Professional Services Agreement with SEH, Inc.

Adopted by the City Council of the City of Waconia this 6th day of April 2026.

\_\_\_\_\_  
Tim Litfin, Mayor

Attest: \_\_\_\_\_  
Jackie Schulze, Assistant City Administrator

## Supplemental Letter Agreement

In accordance with the Agreement for Professional Services between City of Waconia (“Client”), and Short Elliott Hendrickson Inc. (“Consultant”), effective June 2, 2025, this Supplemental Letter Agreement dated April 6, 2026 authorizes and describes the scope, schedule, and payment conditions for Consultant’s work on the Project described as: **Water Treatment Plant No. 4 – Cold Storage Building**.

**Client’s Authorized Representative:** Jon Haukaas

**Address:** 310 East 10th Street, Waconia, MN 55387

**Telephone:** 952.442.4265

**Email:** jhaukaas@waconiamn.gov

**Project Manager:** Kevin Young

**Address:** 3535 Vadnais Center Drive, St. Paul, Minnesota 55110

**Telephone:** 320.229.4306

**Email:** kbyoung@sehinc.com

**Scope:** The Services to be provided by Consultant:

Consultant will design a 200’ x 100’ cold storage building adjacent to the proposed Water Treatment Plant No. 4 (WTP No. 4) and will incorporate the design into the WTP No. 4 project to be bid as an alternate. Design elements of the building will include:

1. Architectural/Structural:
  - a. 18-20’ tall sidewalls on the north side of the building, with a pitched flat roof sloping to the north. Sidewall height will be dictated by providing adequate clearance over 14’ overhead doors.
  - b. High windows (translucent panels) on the south exterior wall for natural lighting.
  - c. One 14’ tall overhead door on each the east and west exterior walls of the building. An egress door will provide next to each overhead door.
  - d. Roofing style is assumed to be similar to that of proposed WTP No. 4.
  - e. Cast-in-place concrete frost footings.
  - f. Uninsulated pre-cast wall panels. Aesthetic of the panels will compliment proposed WTP No. 4. Client does not intend to heat the building in the future.
2. Electrical:
  - a. Outlets will be placed along exterior walls as required by code requirements, plus several located for planned building usage.
  - b. High bay lighting.
3. Mechanical:
  - a. Building ventilation will be provided per code requirements associated with facilities used for storing vehicles.
  - b. Dry-pipe fire suppression system will be required per proposed occupancy.
  - c. Water service within the building will not be provided.
  - d. A center trench drain will be incorporated into the building slab.
4. Civil:
  - a. Utility coordination/extensions for fire suppression system and sanitary sewer connection.

### Schedule:

Consultant will begin work immediately upon notice to proceed. Bidding Documents for the Cold Storage Facility will be completed within four (4) weeks of the NTP and incorporated into the Bidding Documents for Water Treatment Plant No. 4.

**Payment:**

The lump sum fee is \$118,750 including expenses and equipment.

The payment method, basis, frequency and other special conditions are set forth in Exhibit A-2 of the Agreement for Professional Services dated June 2, 2025.

**Other Terms and Conditions:** Other or additional terms contrary to the Agreement for Professional Services that apply solely to this project as specifically agreed to by signature of the Parties and set forth herein:  
None.

**Short Elliott Hendrickson Inc.**

**City of Waconia**

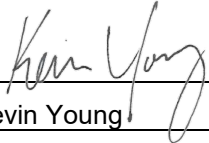
By:   
Full Name: Kevin Young  
Title: Client Service Manager

By: \_\_\_\_\_  
Full Name: TIM LITFIN  
Title: MAYOR



**REQUEST FOR CITY COUNCIL ACTION**

<b>Meeting Date:</b>	April 6, 2026
<b>Item Name:</b>	9.5. Award CSAH 10 Regional Trail Connector Project
<b>Originating Dept:</b>	Public Services
<b>Presented By:</b>	Jon Haukaas
<b>Previous Council Action:</b>	Resolution No. 2026-022 Authorizing the Preparation of Plans and Specifications and Authorizing Advertisement for Bids of the CSAH 10 Connector Trail project
<b>Item Type:</b>	Regular Session

**RECOMMENDATIONS/COUNCIL ACTION/MOTION REQUESTED:** Adopt Resolution No. 2026-102 Authorizing Award of Contract for CSAH 10 Regional Trail Connection project

**EXPLANATION OF AGENDA ITEM:**

A goal of the City has been to connect the City’s trail system to the Sterling Hill neighborhood and also provide a safer alternative to walking/biking on the shoulder of CSAH 10. A trail along CSAH 10 to the north of Sterling Road was originally included in the recent CSAH 10 / Waconia Parkway North roundabout project later removed due to overall budget concerns. Staff has worked with Carver County on commitments for a portion of the construction costs and to develop a Joint Powers Agreement (JPA) detailing the duties and commitments of each party related to this project. This JPA is before you for consideration in a separate action tonight. The Minnesota Department of Natural Resources (DNR) Local Trails Connections Program grant funds obtained in 2024 will be expiring on June 30, 2026. Therefore, the goal has been to complete the trail project from Sterling Road to Waconia Parkway North this upcoming spring.

Bids were opened for the project at 11:00am on March 31, 2026. Seven bids were received and are tabulated below. The low bid was submitted by GMH Asphalt Corporation.

<b>Bidder</b>	<b>Bid Amount</b>
GMH Asphalt Corporation	\$344,905.27
JC Hallet Construction	\$399,979.50
Sunram Construction, Inc.	\$450,059.00
Boulder Creek, Inc.	\$483,644.25
Urban Companies	\$519,899.70

Evaluation of the bids indicates the bidding process was very competitive. The low bid submitted was 36% below the engineer’s estimated amount of \$470,000 and 16% below the next lowest bid. GMH Asphalt Corporation has successfully completed projects of this type in the past and thereby has shown themselves to be a responsible contractor.

Based on the items above, we recommend the City award a contract in the amount of \$344,905.27 to GMH Asphalt Corporation.

**ATTACHMENTS:**

1. Resolution No. 2026-102 Contract CSAH 10 Regional Trail Connection
2. CSAH 10 Trail Connection Bids

<b>FINANCIAL IMPLICATIONS:</b>	<b>ADVISORY BOARD RECOMMENDATIONS:</b>
Funding Sources & Uses: Budget Information: <input checked="" type="checkbox"/> Budgeted _____ Non-Budgeted _____ Amendment Required	Planning Commission: _____ Park Board: _____ Personnel Committee: _____ Other: _____

**CITY OF WACONIA  
RESOLUTION NO. 2026-102**

**RESOLUTION AUTHORIZING AWARD  
OF CONSTRUCTION CONTRACT FOR THE  
HIGHWAY 10 REGIONAL TRAIL CONNECTION PROJECT**

**WHEREAS**, the City Council authorized on January 5, 2026, to prepare plans and specifications and to publicly solicit bids for the CSAH 10 Regional Trail Connection project; and

**WHEREAS**, the project is being constructed under a Joint Powers Agreement with Carver County which allows the City to lead and award the work; and

**WHEREAS**, time is of the essence due to DNR Grant requirements that the project be under contract for construction by June 30, 2026, therefore it is recommended to authorize this work to complete the trail project from Sterling Road to Waconia Parkway North; and

**WHEREAS**, bids from seven contractors were received virtually on March 31, 2026, at 11:00 a.m.; and

**WHEREAS**, Staff and City Engineer recommend award of the CSAH 10 Regional Trail Connection Project to GMH Asphalt Corporation who have successfully completed projects of this scale and scope.

**NOW, THEREFORE, BE IT RESOLVED** That the City Council of the City of Waconia hereby authorizes award of Construction Contract for the CSAH 10 Regional Trail Connection Project in the amount of \$344,905.27 to GMH Asphalt Corporation.

Adopted by the City Council of the City of Waconia this 6<sup>th</sup> day of April 2026.

\_\_\_\_\_  
Tim Litfin, Mayor

Attest: \_\_\_\_\_  
Jackie Schulze, City Clerk



**BOLTON  
& MENK**

Real People. Real Solutions.

2638 Shadow Lane  
Suite 200  
Chaska, MN 55318-1172

Ph: (952) 448-8838  
Fax: (952) 448-8805  
Bolton-Menk.com

April 1, 2026

City of Waconia  
Attn: Jon Haukaas  
310 10<sup>th</sup> Street East  
Waconia, MN 55387

**Re: CSAH 10 Trail Award Recommendation**

Dear Mr. Haukaas,

Bids were received and opened electronically through QuestCDN on March 31, 2026 for the project reference above. Seven (7) bids were received, and the results of the bids are tabulated below:

<u>Bidder</u>	<u>Bid Amount</u>
GMH Asphalt Corporation	\$344,905.27
JC Hallet Construction	\$399,979.50
Sunram Construction, Inc.	\$450,059.00
S.M. Hentges & Sons, Inc.	\$483,644.25
Boulder Creek, Inc.	\$513,966.40
Minger Construction Co. Inc.	\$519,899.70
Urban Companies	\$598,837.80

The low bidder for the project is GMH Asphalt Corporation, from Chaska, Minnesota. The low bid submitted was 36% below the Engineer's Estimate and 16% below the next lowest bid.

GMH Asphalt Corporation has successfully completed projects of this type in the past and have thereby shown themselves to be a responsible contractor. Based on the items above, it is recommended the City award a construction contract in the amount of **\$344,905.27** to GMH Asphalt. I am open to discuss this information with you and answer any questions that you or the City Council may have.

Respectfully Submitted,  
**BOLTON & MENK, INC.**

Jake Saulsbury, P.E.

cc: Nicole Meyer, Finance Director  
Ryan Johnson, Bolton & Menk



## REQUEST FOR CITY COUNCIL ACTION

<b>Meeting Date:</b>	April 6, 2026
<b>Item Name:</b>	9.6. Provide for the Issuance and Sale of General Obligation Bonds, Series 2026A and 2026B and Call a Public Hearing for Issuance
<b>Originating Dept:</b>	Finance
<b>Presented By:</b>	Nicole Meyer
<b>Previous Council Action:</b> None	
<b>Item Type:</b>	Regular Session
<b>RECOMMENDATIONS/COUNCIL ACTION/MOTION REQUESTED:</b> Adopt Resolution No. 2026-103 Providing for the Issuance and Sale of \$9,520,000 General Obligation Bonds, Series 2026A  Adopt Resolution No. 2026-104 Providing for the Issuance and Sale of \$3,265,000 General Obligation Temporary Street Reconstruction Bonds, Series 2026B  Adopt Resolution No. 2026-105 Calling a Public Hearing on the Proposal to Adopt a Street Reconstruction Plan and the Intent to Issue General Obligation Street Reconstruction Bonds	
<b>EXPLANATION OF AGENDA ITEM:</b>  Staff has been working with Ehler's on the issuance of bonds to fund the 2026 infrastructure improvement project, a budgeted portion of the City's 2026 mill and overlay project, and construction of the Reitz Lake Lift Station. The City budgeted to issue General Obligation 429 special assessment bonds and revenue bonds to fund the project costs. In addition to these budgeted items, staff is requesting the issuance of temporary street reconstruction bonds for costs associated with the Highway 5 Phase 2 construction project that is set to be constructed in 2027. Issuing these temporary bonds will assist with cash flow as most of the aid being received for the project will be reimbursed after bids are approved and construction expenses are incurred. Attached "Exhibit A" is breakdown of the 2026 projects along with their identified funding sources.  General Obligation special assessment 429 bonds are being issued for the street, sidewalk, signage, and streetlight reconstruction in the downtown area. These improvements are planned to be repaid with special assessment payments from property owners in the area of the improvements. In addition, the City will issue a new special debt levy for the portions not paid by special assessments.  General Obligation 115 bonds are bonds that can be issued only for sanitary sewer projects. Under Minnesota Statute 115.46, the City may issue these bonds to aid in financing sewer projects and repay the debt using special assessments, revenue, or a special debt levy if needed. Currently, the City plans to pay these bonds with revenues from the sanitary sewer fund.  General Obligation 444 revenue bonds will be issued for those portions of the projects related to water and storm water. These are revenue bonds that must be repaid with revenues in the	

enterprise funds from sales paid by the City’s customer base and trunk fees.

General Obligation 475 bonds can be issued for street reconstruction purposes. The City must hold a public hearing and allow a 30-day reverse referendum period for the issuance of the bonds and to approve the street reconstruction plan. The public hearing will be held on May 4, 2026. The reverse referendum period ends on June 3, 2026. The bonds being issued are temporary bonds and repayments will be made with reimbursements provided for the construction of the Highway 5 Phase 2 project. No new special debt levy will be established for these bonds.

Todd Hagen from Ehlers will be at the meeting to present to the City Council the attached pre-sale reports for the bonds along with the resolutions to be considered for approval. This step will allow City staff to continue in the next steps of the issuance of bonds for the financing of these projects.

Staff will finalize the amount of the final bond issue after approval of the project bid and calculation of the special assessments.

**ATTACHMENTS:**

1. Resolution No. 2026-103 Waconia 2026A Presale Street Reconstruction
2. Pre-Sale Report Waconia.2026A
3. Resolution No. 2026-104 Waconia 2026B Presale Street Reconstruction
4. Pre-Sale Report Waconia 2026B
5. Resolution No. 2026-105 Public Hearing 2026B for Street Reconstruction Plan & Street Reconstruction Bonds
6. Breakdown of Debt Issuance Exhibit A

<b>FINANCIAL IMPLICATIONS:</b>	<b>ADVISORY BOARD RECOMMENDATIONS:</b>
Funding Sources & Uses: Special Debt Tax Levy, Water, Sewer, and Storm Water Utility Funds Budget Information: <input checked="" type="checkbox"/> Budgeted _____ Non-Budgeted _____ Amendment Required	Planning Commission: _____ Park Board: _____ Personnel Committee: _____ Other: _____

EXTRACT OF MINUTES OF A MEETING OF THE  
CITY COUNCIL OF THE CITY OF WACONIA, MINNESOTA

HELD: APRIL 6, 2026

Pursuant to due call and notice thereof, a regular or special meeting of the City Council of the City of Waconia, Carver County, Minnesota, was duly held at City Hall on April 6, 2026, at 6:00 P.M., for the purpose, in part, of providing for the issuance and sale of \$9,520,000 General Obligation Bonds, Series 2026A.

The following members were present: LITFIN, GRENGS, COLEMAN, GLEASON,  
AND SIDDONSON

and the following were absent: NONE

Member \_\_\_\_\_ introduced the following resolution and moved its adoption:

RESOLUTION NO. 2026-103

RESOLUTION PROVIDING FOR THE ISSUANCE AND SALE OF  
\$9,520,000 GENERAL OBLIGATION BONDS, SERIES 2026A

A. WHEREAS, the City Council (the "Council") of the City of Waconia, Minnesota (the "City") has heretofore determined that it is necessary and expedient to issue the City's \$9,520,000 General Obligation Bonds, Series 2026A (the "Bonds"), to finance the construction of various street and utility system improvements in the City; and

B. WHEREAS, the City has retained Ehlers & Associates, Inc., in Minneapolis, Minnesota ("Ehlers"), as its independent municipal advisor for the Bonds in accordance with Minnesota Statutes, Section 475.60, Subdivision 2(9).

NOW, THEREFORE, BE IT RESOLVED by the City of Waconia, Minnesota, as follows:

1. Authorization. The Council hereby authorizes Ehlers to assist the City for the sale of the Bonds.

2. Meeting; Proposal Opening. The Council shall meet at 6:00 P.M. on June 15, 2026, for the purpose of considering proposals for and awarding the sale of the Bonds.

3. Official Statement. In connection with said sale, the officers or employees of the City are hereby authorized to cooperate with Ehlers and participate in the preparation of an official statement for the Bonds and to execute and deliver it on behalf of the City upon its completion.

The motion for the adoption of the foregoing resolution was duly seconded by Council Member \_\_\_\_\_ and, after full discussion thereof and upon a vote being taken thereon, the following Council Members voted in favor thereof:

and the following voted against the same: LITFIN, GRENGS, COLEMAN, GLEASON, AND  
SIDDONS

Whereupon said resolution was declared duly passed and adopted.

STATE OF MINNESOTA  
CARVER COUNTY  
CITY OF WACONIA

I, the undersigned, being the duly qualified and acting City Administrator of the City of Waconia, Minnesota, DO HEREBY CERTIFY that I have compared the attached and foregoing extract of minutes with the original thereof on file in my office, and that the same is a full, true and complete transcript of the minutes of a meeting of the City Council, duly called and held on the date therein indicated, insofar as the minutes relate to providing for the issuance and sale of \$9,520,000 General Obligation Bonds, Series 2026A.

WITNESS my hand on April 6, 2026.

---

Shane Fineran, City Administrator

April 6, 2026

PRE-SALE REPORT FOR

## City of Waconia, Minnesota

**\$9,520,000 General Obligation Bonds, Series 2026A**



---

**Prepared by:**

Ehlers  
3001 Broadway Street, Suite 320  
Minneapolis, MN 55413

**Advisors:**

Todd Hagen, Senior Municipal Advisor  
Bruce Kimmel, Senior Municipal Advisor  
Keith Dahl, Senior Municipal Advisor

---

**BUILDING COMMUNITIES. IT'S WHAT WE DO.**

# EXECUTIVE SUMMARY OF PROPOSED DEBT

## Proposed Issue:

\$9,520,000 General Obligation Bonds, Series 2026A

The City has directed Ehlers to assist in a financing method that combines three issuance authorities into one bond, does not require voter approval, and would allow for payments over 10 years.

## Purposes:

The proposed issue includes fixed rate/tax-exempt financing for the construction of various street and utility system improvements in the City.

- **Street Improvement Portion (\$4,830,000).** Debt service will be paid from special assessments and property taxes.
- **Water and Storm Sewer Portion (\$1,215,000).** Debt service will be paid from water and storm sewer revenues.
- **Sanitary Sewer Portion (\$3,475,000).** Debt service will be paid from property taxes to be reduced or cancelled with available sanitary sewer revenues.

## Authority:

The Bonds are being issued pursuant to Minnesota Statutes, Chapters:

- 475 (general bonding authority)
- 429 (special assessment pledge)
- 444 (water and sewer revenue pledge)
- 115 (sanitary sewer tax levy pledge)

Because the City is assessing at least 20% of the project costs, the Street Improvement Portion of the Bonds can be a general obligation without a referendum and will not count against the City's debt limit.

Chapter 444 allows cities to issue debt without limitation if debt service is expected to be paid from water and sewer revenues.

Chapter 115 allows bonds for disposal systems to be issued without a referendum and will not count against the City's debt limit.

The City has held the required public hearings and is under the maximum debt limit proscribed in each statutory authority.

The Bonds do not count against the Net Debt Limit of 3% of the estimated market value of taxable property in the City.

The Bonds will be general obligations of the City for which its full faith, credit and taxing powers are pledged.

### **Term/Call Feature:**

The Bonds are being issued for a term of 10 years. Principal on the Bonds will be due on February 1 in the years 2028 through 2037. Interest is payable every six months beginning February 1, 2027. A portion of the Bond proceeds will be used to make the February 1, 2027 interest payment.

The Bonds will be subject to prepayment at the discretion of the City on February 1, 2034 or any date thereafter.

### **Not Bank Qualified:**

Because the City is expecting to issue more than \$10,000,000 in tax exempt debt during the calendar year, the City will not be able to designate the Bonds as “bank qualified” obligations.

Bank qualified status broadens the market for the Bonds, which can result in lower interest rates.

### **Rating:**

The City’s most recent bond issues were rated by S&P Global Ratings. The current rating on those bonds is “AA+”. The City will request a new rating for the Bonds.

If the winning bidder on the Bonds elects to purchase bond insurance, the rating for the issue may be higher than the City’s bond rating if the bond rating of the insurer is higher than that of the City.

### **Basis for Recommendation:**

Based on our knowledge of the City’s situation, their objectives communicated to us, our advisory relationship as well as characteristics of various financing options, we are recommending the issuance of general obligation bonds with a full competitive sale as a suitable financing option for the following reasons:

- General obligation bonds provide a straight-forward approach to financing projects identified by the City.
- We expect that the size and term of the issue, with bank qualification and a high bond rating, will attract several quality bids based upon similar recent sales in Minnesota.
- The City does not expect to have surplus resources adequate to prepay the debt prior to the scheduled maturities.
- This is generally the most overall cost-effective option.

Because of its larger size, we are recommending against offering the Bonds to a limited number of local and regional banks and selling this issue rated through a full competitive process to the public market using an official statement. Also, there are no special circumstances that would require a negotiated sale. This method of sale complies with City

policy as well as best practices endorsed by the Government Finance Officers Association (GFOA).

### **Method of Sale/Placement:**

We will solicit competitive bids for the sale of the Bonds to underwriters and banks as the size, structure and term will likely result in the maximum number of bids at the lowest interest rates and is a desirable credit for municipal bond investors.

We will include an allowance for discount bidding in the terms of the issue. The discount is treated as an interest item and provides the underwriter with all or a portion of their compensation in the transaction.

If the Bonds are purchased at a price greater than the minimum bid amount (maximum discount), the unused allowance may be used to reduce your borrowing amount.

### **Premium Pricing:**

In some cases, investors in municipal bonds prefer “premium” pricing structures. A premium is achieved when the coupon for any maturity (the interest rate paid by the issuer) exceeds the yield to the investor, resulting in a price paid that is greater than the face value of the bonds. The sum of the amounts paid more than face value is considered “reoffering premium.” The underwriter of the bonds will retain a portion of this reoffering premium as their compensation (or “discount”) but will pay the remainder of the premium to the City.

For this issue of Bonds, we have been directed to use the net premium to reduce the size of the issue rather than increase the net proceeds for the project; but that could change on the day of sale. The resulting adjustments may slightly change the true interest cost of the issue, either up or down.

### **Review of Existing Debt:**

We have reviewed all outstanding indebtedness for the City and find that there are no refunding opportunities at this time.

We will continue to monitor the market and the call dates for the City’s outstanding debt and will alert you to any future refunding opportunities.

### **Continuing Disclosure:**

Because the City has more than \$10,000,000 in outstanding debt subject to a continuing disclosure undertaking (including this issue) and this issue does not meet an available exemption from continuing disclosure, the City will be agreeing to provide certain updated Annual Financial Information and its Audited Financial Statements annually, as well as providing notices of the occurrence of certain reportable events to the Municipal Securities Rulemaking Board (the “MSRB”), as required by rules of the Securities and Exchange Commission (SEC).

The City is already obligated to provide such reports for its existing bonds and has contracted with Ehlers to prepare and file the reports.

## Arbitrage Monitoring:

The City must ensure compliance with certain sections of the Internal Revenue Code and Treasury Regulations (“Arbitrage Rules”) throughout the life of the issue to maintain the tax-exempt status of the Bonds. These Arbitrage Rules apply to amounts held in construction, escrow, reserve, debt service account(s), etc., along with related investment income on each fund/account.

IRS audits will verify compliance with rebate, yield restriction and records retention requirements within the Arbitrage Rules. The City’s specific arbitrage responsibilities will be detailed in the Nonarbitrage Certificate prepared by your bond attorney and provided at closing.

**Two-Year (24-month) Spending Exception** - The City expects to meet the two-year expenditure exception on the Bond proceeds. If the City fails to meet the expenditure exceptions, it will be required to pay rebate.

We recommend that the City review its specific responsibilities related to the Bonds with an arbitrage expert to help monitor the exception used above.

An Ehlers arbitrage expert will contact the City within 30 days after the sale date to review the City’s specific responsibilities for the Bonds. The City is currently receiving arbitrage services from Ehlers in relation to the Bonds.

## Investment of Bond Proceeds:

Ehlers can assist the City in developing a strategy to invest your Bond proceeds until the funds are needed to pay project costs.

## Risk Factors:

**Special Assessments:** We have not assumed any prepaid special assessments, and we have assumed that assessments will be levied as projected. If the City receives a significant number of prepaid assessments or does not levy the assessments, it may need to increase the levy portion of the debt service to make up for lower interest earnings than the expected assessment interest rate.

**Water and Sewer Revenues:** The City expects to pay a portion of the Bond debt service with water and sewer funds. If water and sewer revenues are inadequate, the City may have to levy taxes to pay debt service on the Bonds.

**GO Pledge:** Because the Bonds will be general obligations of the City for which its full faith, credit and taxing powers are pledged, if the annual special assessments, water and sewer revenues, and tax levy collected are not sufficient to pay the debt service payments, other City funds will need to be used.

## Other Service Providers:

This debt issuance will require the engagement of other public finance service providers. This section identifies those other service providers, so Ehlers can coordinate their engagement on your behalf. Where you have previously used a particular firm to provide a service, we have assumed that you will continue that relationship. For services you have not previously required, we have identified a service provider. Fees charged by these service providers will

be paid from proceeds of the obligation, unless you notify us that you wish to pay them from other sources. Our pre-sale bond sizing includes a good faith estimate of these fees, but the final fees may vary. If you have any questions pertaining to the identified service providers or their role, or if you would like to use a different service provider for any of the listed services, please contact us.

**Bond Counsel:** Taft Stettinius & Hollister

**Paying Agent:** Bond Trust Services

**Rating Agency:** S&P Global Ratings

### **Summary:**

The decisions to be made by the City Council are as follows:

- Accept or modify the finance assumptions described in this report.
- Adopt the resolution attached to this report.

This pre-sale report summarizes our understanding of the City's objectives for the structure and terms of this financing as of this date. As additional facts become known or capital markets conditions change, we may need to modify the structure and/or terms of this financing to achieve results consistent with the City's objectives.

## PROPOSED DEBT ISSUANCE SCHEDULE

Pre-Sale Review by City Council:	April 6, 2026
Due Diligence Call to review Official Statement/Conference with Rating Agency:	Week of June 1, 2026
Print Official Statement:	June 4, 2026
City Council Meeting to Award Sale of the Bonds:	June 15, 2026
Estimated Closing Date:	July 2, 2026

### Attachments

- Estimated Sources and Uses of Funds
- Estimated Proposed Debt Service Schedule
- Bond Buyer Index
- Resolution Authorizing Ehlers to Proceed with Bond Sale (provided separately)

## EHLERS' CONTACTS

Todd Hagen, Senior Municipal Advisor	(651) 697-8508
Bruce Kimmel, Senior Municipal Advisor	(651) 697-8572
Keith Dahl, Senior Municipal Advisor	(651) 697-8595
Silvia Johnson, Lead Public Finance Analyst	(651) 697-8580
Alicia Gage, Senior Financial Analyst	(651) 697-8551

# City of Waconia, Minnesota

\$9,510,000 GO Bonds, Series 2026A Issue Summary  
 Assumes Current Market Non-BQ "AA+" Rates plus 50bps

## Total Issue Sources And Uses

Dated 07/02/2026 | Delivered 07/02/2026

	Improvements (429)	Water (444)	Storm Sewer (444)	Sanitary Sewer (115)	Issue Summary
<b>Sources Of Funds</b>					
Par Amount of Bonds	\$4,825,000.00	\$960,000.00	\$255,000.00	\$3,470,000.00	\$9,510,000.00
<b>Total Sources</b>	<b>\$4,825,000.00</b>	<b>\$960,000.00</b>	<b>\$255,000.00</b>	<b>\$3,470,000.00</b>	<b>\$9,510,000.00</b>
<b>Uses Of Funds</b>					
Total Underwriter's Discount (1.000%)	48,250.00	9,600.00	2,550.00	34,700.00	95,100.00
Costs of Issuance	60,375.94	12,012.61	3,190.84	43,420.61	119,000.00
Deposit to Capitalized Interest (CIF) Fund	98,504.31	-	-	-	98,504.31
Deposit to Project Construction Fund	4,616,182.69	938,660.00	247,016.00	3,395,225.00	9,197,083.69
Rounding Amount	1,687.06	(272.61)	2,243.16	(3,345.61)	312.00
<b>Total Uses</b>	<b>\$4,825,000.00</b>	<b>\$960,000.00</b>	<b>\$255,000.00</b>	<b>\$3,470,000.00</b>	<b>\$9,510,000.00</b>

# City of Waconia, Minnesota

\$9,510,000 GO Bonds, Series 2026A Issue Summary  
Assumes Current Market Non-BQ "AA+" Rates plus 50bps

## Debt Service Schedule

Date	Principal	Coupon	Interest	Total P+I	Fiscal Total
07/02/2026	-	-	-	-	-
02/01/2027	-	-	194,143.59	194,143.59	194,143.59
08/01/2027	-	-	167,205.00	167,205.00	-
02/01/2028	815,000.00	3.050%	167,205.00	982,205.00	1,149,410.00
08/01/2028	-	-	154,776.25	154,776.25	-
02/01/2029	850,000.00	3.100%	154,776.25	1,004,776.25	1,159,552.50
08/01/2029	-	-	141,601.25	141,601.25	-
02/01/2030	870,000.00	3.200%	141,601.25	1,011,601.25	1,153,202.50
08/01/2030	-	-	127,681.25	127,681.25	-
02/01/2031	895,000.00	3.300%	127,681.25	1,022,681.25	1,150,362.50
08/01/2031	-	-	112,913.75	112,913.75	-
02/01/2032	930,000.00	3.400%	112,913.75	1,042,913.75	1,155,827.50
08/01/2032	-	-	97,103.75	97,103.75	-
02/01/2033	955,000.00	3.500%	97,103.75	1,052,103.75	1,149,207.50
08/01/2033	-	-	80,391.25	80,391.25	-
02/01/2034	990,000.00	3.600%	80,391.25	1,070,391.25	1,150,782.50
08/01/2034	-	-	62,571.25	62,571.25	-
02/01/2035	1,025,000.00	3.750%	62,571.25	1,087,571.25	1,150,142.50
08/01/2035	-	-	43,352.50	43,352.50	-
02/01/2036	1,070,000.00	3.850%	43,352.50	1,113,352.50	1,156,705.00
08/01/2036	-	-	22,755.00	22,755.00	-
02/01/2037	1,110,000.00	4.100%	22,755.00	1,132,755.00	1,155,510.00
<b>Total</b>	<b>\$9,510,000.00</b>	<b>-</b>	<b>\$2,214,846.09</b>	<b>\$11,724,846.09</b>	<b>-</b>

## Yield Statistics

Bond Year Dollars	\$60,466.08
Average Life	6.358 Years
Average Coupon	3.6629561%
Net Interest Cost (NIC)	3.8202344%
True Interest Cost (TIC)	3.8314861%
Bond Yield for Arbitrage Purposes	3.6494327%
All Inclusive Cost (AIC)	4.0628582%

## IRS Form 8038

Net Interest Cost	3.6629561%
Weighted Average Maturity	6.358 Years

# City of Waconia, Minnesota

\$9,510,000 GO Bonds, Series 2026A Issue Summary  
 Assumes Current Market Non-BQ "AA+" Rates plus 50bps

## Net Debt Service Schedule

Date	Principal	Coupon	Interest	Total P+I	CIF	Net New D/S	Fiscal Total
07/02/2026	-	-	-	-	-	-	-
02/01/2027	-	-	194,143.59	194,143.59	(98,504.31)	95,639.28	95,639.28
08/01/2027	-	-	167,205.00	167,205.00	-	167,205.00	-
02/01/2028	815,000.00	3.050%	167,205.00	982,205.00	-	982,205.00	1,149,410.00
08/01/2028	-	-	154,776.25	154,776.25	-	154,776.25	-
02/01/2029	850,000.00	3.100%	154,776.25	1,004,776.25	-	1,004,776.25	1,159,552.50
08/01/2029	-	-	141,601.25	141,601.25	-	141,601.25	-
02/01/2030	870,000.00	3.200%	141,601.25	1,011,601.25	-	1,011,601.25	1,153,202.50
08/01/2030	-	-	127,681.25	127,681.25	-	127,681.25	-
02/01/2031	895,000.00	3.300%	127,681.25	1,022,681.25	-	1,022,681.25	1,150,362.50
08/01/2031	-	-	112,913.75	112,913.75	-	112,913.75	-
02/01/2032	930,000.00	3.400%	112,913.75	1,042,913.75	-	1,042,913.75	1,155,827.50
08/01/2032	-	-	97,103.75	97,103.75	-	97,103.75	-
02/01/2033	955,000.00	3.500%	97,103.75	1,052,103.75	-	1,052,103.75	1,149,207.50
08/01/2033	-	-	80,391.25	80,391.25	-	80,391.25	-
02/01/2034	990,000.00	3.600%	80,391.25	1,070,391.25	-	1,070,391.25	1,150,782.50
08/01/2034	-	-	62,571.25	62,571.25	-	62,571.25	-
02/01/2035	1,025,000.00	3.750%	62,571.25	1,087,571.25	-	1,087,571.25	1,150,142.50
08/01/2035	-	-	43,352.50	43,352.50	-	43,352.50	-
02/01/2036	1,070,000.00	3.850%	43,352.50	1,113,352.50	-	1,113,352.50	1,156,705.00
08/01/2036	-	-	22,755.00	22,755.00	-	22,755.00	-
02/01/2037	1,110,000.00	4.100%	22,755.00	1,132,755.00	-	1,132,755.00	1,155,510.00
<b>Total</b>	<b>\$9,510,000.00</b>	<b>-</b>	<b>\$2,214,846.09</b>	<b>\$11,724,846.09</b>	<b>(98,504.31)</b>	<b>\$11,626,341.78</b>	<b>-</b>

## Significant Dates

Dated 7/02/2026  
 First available call date

# City of Waconia, Minnesota

\$9,510,000 GO Bonds, Series 2026A Issue Summary

Assumes Current Market Non-BQ "AA+" Rates plus 50bps

## Debt Service Schedule

Date	Principal	Coupon	Interest	Total P+I	CIF	Net New D/S	105% of Total	Assessments	Water Revenue	Storm Sewer Revenue	Levy/(Surplus)
02/01/2027	-	-	194,143.59	194,143.59	(98,504.31)	95,639.28	100,421.24	-	20,581.06	5,460.35	74,379.84
02/01/2028	815,000.00	3.050%	334,410.00	1,149,410.00	-	1,149,410.00	1,206,880.50	132,735.54	119,450.63	30,405.38	924,288.96
02/01/2029	850,000.00	3.100%	309,552.50	1,159,552.50	-	1,159,552.50	1,217,530.13	132,735.54	122,138.63	35,014.88	927,641.09
02/01/2030	870,000.00	3.200%	283,202.50	1,153,202.50	-	1,153,202.50	1,210,862.63	132,735.54	124,621.88	34,201.13	919,304.09
02/01/2031	895,000.00	3.300%	255,362.50	1,150,362.50	-	1,150,362.50	1,207,880.63	132,735.53	121,597.88	33,361.13	920,186.10
02/01/2032	930,000.00	3.400%	225,827.50	1,155,827.50	-	1,155,827.50	1,213,618.88	132,735.53	123,729.38	32,494.88	924,659.10
02/01/2033	955,000.00	3.500%	194,207.50	1,149,207.50	-	1,149,207.50	1,206,667.88	132,735.53	120,337.88	31,602.38	921,992.10
02/01/2034	990,000.00	3.600%	160,782.50	1,150,782.50	-	1,150,782.50	1,208,321.63	132,735.54	122,096.63	30,683.63	922,805.84
02/01/2035	1,025,000.00	3.750%	125,142.50	1,150,142.50	-	1,150,142.50	1,207,649.63	132,735.54	123,566.63	29,738.63	921,608.84
02/01/2036	1,070,000.00	3.850%	86,705.00	1,156,705.00	-	1,156,705.00	1,214,540.25	132,735.53	124,682.25	34,004.25	923,118.22
02/01/2037	1,110,000.00	4.100%	45,510.00	1,155,510.00	-	1,155,510.00	1,213,285.50	132,735.52	120,235.50	32,791.50	927,522.98
<b>Total</b>	<b>\$9,510,000.00</b>	<b>-</b>	<b>\$2,214,846.09</b>	<b>\$11,724,846.09</b>	<b>(98,504.31)</b>	<b>\$11,626,341.78</b>	<b>\$12,207,658.87</b>	<b>\$1,327,355.34</b>	<b>\$1,243,038.31</b>	<b>\$329,758.10</b>	<b>\$9,307,507.12</b>

## Significant Dates

Dated	7/02/2026
First Coupon Date	2/01/2027

## Yield Statistics

Bond Year Dollars	\$60,466.08
Average Life	6.358 Years
Average Coupon	3.6629561%
Net Interest Cost (NIC)	3.8202344%
True Interest Cost (TIC)	3.8314861%
Bond Yield for Arbitrage Purposes	3.6494327%
All Inclusive Cost (AIC)	4.0628582%

# City of Waconia, Minnesota

\$4,825,000 GO Bonds, Series 2026A Improvements (429)

## Debt Service Schedule

Date	Principal	Coupon	Interest	Total P+I	Fiscal Total
07/02/2026	-	-	-	-	-
02/01/2027	-	-	98,504.31	98,504.31	98,504.31
08/01/2027	-	-	84,836.25	84,836.25	-
02/01/2028	415,000.00	3.050%	84,836.25	499,836.25	584,672.50
08/01/2028	-	-	78,507.50	78,507.50	-
02/01/2029	430,000.00	3.100%	78,507.50	508,507.50	587,015.00
08/01/2029	-	-	71,842.50	71,842.50	-
02/01/2030	440,000.00	3.200%	71,842.50	511,842.50	583,685.00
08/01/2030	-	-	64,802.50	64,802.50	-
02/01/2031	455,000.00	3.300%	64,802.50	519,802.50	584,605.00
08/01/2031	-	-	57,295.00	57,295.00	-
02/01/2032	470,000.00	3.400%	57,295.00	527,295.00	584,590.00
08/01/2032	-	-	49,305.00	49,305.00	-
02/01/2033	485,000.00	3.500%	49,305.00	534,305.00	583,610.00
08/01/2033	-	-	40,817.50	40,817.50	-
02/01/2034	505,000.00	3.600%	40,817.50	545,817.50	586,635.00
08/01/2034	-	-	31,727.50	31,727.50	-
02/01/2035	520,000.00	3.750%	31,727.50	551,727.50	583,455.00
08/01/2035	-	-	21,977.50	21,977.50	-
02/01/2036	540,000.00	3.850%	21,977.50	561,977.50	583,955.00
08/01/2036	-	-	11,582.50	11,582.50	-
02/01/2037	565,000.00	4.100%	11,582.50	576,582.50	588,165.00
<b>Total</b>	<b>\$4,825,000.00</b>	<b>-</b>	<b>\$1,123,891.81</b>	<b>\$5,948,891.81</b>	<b>-</b>

## Yield Statistics

Bond Year Dollars	\$30,681.18
Average Life	6.359 Years
Average Coupon	3.6631309%
Net Interest Cost (NIC)	3.8203934%
True Interest Cost (TIC)	3.8316452%
Bond Yield for Arbitrage Purposes	3.6494327%
All Inclusive Cost (AIC)	4.0629997%

## IRS Form 8038

Net Interest Cost	3.6631309%
Weighted Average Maturity	6.359 Years

# City of Waconia, Minnesota

\$4,825,000 GO Bonds, Series 2026A Improvements (429)

## Net Debt Service Schedule

Date	Principal	Coupon	Interest	Total P+I	CIF	Net New D/S	Fiscal Total
07/02/2026	-	-	-	-	-	-	-
02/01/2027	-	-	98,504.31	98,504.31	(98,504.31)	-	-
08/01/2027	-	-	84,836.25	84,836.25	-	84,836.25	-
02/01/2028	415,000.00	3.050%	84,836.25	499,836.25	-	499,836.25	584,672.50
08/01/2028	-	-	78,507.50	78,507.50	-	78,507.50	-
02/01/2029	430,000.00	3.100%	78,507.50	508,507.50	-	508,507.50	587,015.00
08/01/2029	-	-	71,842.50	71,842.50	-	71,842.50	-
02/01/2030	440,000.00	3.200%	71,842.50	511,842.50	-	511,842.50	583,685.00
08/01/2030	-	-	64,802.50	64,802.50	-	64,802.50	-
02/01/2031	455,000.00	3.300%	64,802.50	519,802.50	-	519,802.50	584,605.00
08/01/2031	-	-	57,295.00	57,295.00	-	57,295.00	-
02/01/2032	470,000.00	3.400%	57,295.00	527,295.00	-	527,295.00	584,590.00
08/01/2032	-	-	49,305.00	49,305.00	-	49,305.00	-
02/01/2033	485,000.00	3.500%	49,305.00	534,305.00	-	534,305.00	583,610.00
08/01/2033	-	-	40,817.50	40,817.50	-	40,817.50	-
02/01/2034	505,000.00	3.600%	40,817.50	545,817.50	-	545,817.50	586,635.00
08/01/2034	-	-	31,727.50	31,727.50	-	31,727.50	-
02/01/2035	520,000.00	3.750%	31,727.50	551,727.50	-	551,727.50	583,455.00
08/01/2035	-	-	21,977.50	21,977.50	-	21,977.50	-
02/01/2036	540,000.00	3.850%	21,977.50	561,977.50	-	561,977.50	583,955.00
08/01/2036	-	-	11,582.50	11,582.50	-	11,582.50	-
02/01/2037	565,000.00	4.100%	11,582.50	576,582.50	-	576,582.50	588,165.00
<b>Total</b>	<b>\$4,825,000.00</b>	<b>-</b>	<b>\$1,123,891.81</b>	<b>\$5,948,891.81</b>	<b>(98,504.31)</b>	<b>\$5,850,387.50</b>	<b>-</b>

## Significant Dates

Dated 7/02/2026  
 First available call date

# City of Waconia, Minnesota

\$4,825,000 GO Bonds, Series 2026A Improvements (429)

## Debt Service Schedule

Date	Principal	Coupon	Interest	Total P+	CIF	Net New D/S	105% of Total	Assessments	Levy/(Surplus)
02/01/2027	-	-	98,504.31	98,504.31	(98,504.31)	-	-	-	-
02/01/2028	415,000.00	3.050%	169,672.50	584,672.50	-	584,672.50	613,906.13	132,735.54	481,170.59
02/01/2029	430,000.00	3.100%	157,015.00	587,015.00	-	587,015.00	616,365.75	132,735.54	483,630.21
02/01/2030	440,000.00	3.200%	143,685.00	583,685.00	-	583,685.00	612,869.25	132,735.54	480,133.71
02/01/2031	455,000.00	3.300%	129,605.00	584,605.00	-	584,605.00	613,835.25	132,735.53	481,099.72
02/01/2032	470,000.00	3.400%	114,590.00	584,590.00	-	584,590.00	613,819.50	132,735.53	481,083.97
02/01/2033	485,000.00	3.500%	98,610.00	583,610.00	-	583,610.00	612,790.50	132,735.53	480,054.97
02/01/2034	505,000.00	3.600%	81,635.00	586,635.00	-	586,635.00	615,966.75	132,735.54	483,231.21
02/01/2035	520,000.00	3.750%	63,455.00	583,455.00	-	583,455.00	612,627.75	132,735.54	479,892.21
02/01/2036	540,000.00	3.850%	43,955.00	583,955.00	-	583,955.00	613,152.75	132,735.53	480,417.22
02/01/2037	565,000.00	4.100%	23,165.00	588,165.00	-	588,165.00	617,573.25	132,735.52	484,837.73
<b>Total</b>	<b>\$4,825,000.00</b>	<b>-</b>	<b>\$1,123,891.81</b>	<b>\$5,948,891.81</b>	<b>(98,504.31)</b>	<b>\$5,850,387.50</b>	<b>\$6,142,906.88</b>	<b>\$1,327,355.34</b>	<b>\$4,815,551.54</b>

## Significant Dates

Dated	7/02/2026
First Coupon Date	2/01/2027

## Yield Statistics

Bond Year Dollars	\$30,681.18
Average Life	6.359 Years
Average Coupon	3.6631309%
Net Interest Cost (NIC)	3.8203934%
True Interest Cost (TIC)	3.8316452%
Bond Yield for Arbitrage Purposes	3.6494327%
All Inclusive Cost (AIC)	4.0629997%

# City of Waconia, Minnesota

\$960,000 GO Bonds, Series 2026A Water (444)

## Debt Service Schedule

Date	Principal	Coupon	Interest	Total P+I	Fiscal Total
07/02/2026	-	-	-	-	-
02/01/2027	-	-	19,601.01	19,601.01	19,601.01
08/01/2027	-	-	16,881.25	16,881.25	-
02/01/2028	80,000.00	3.050%	16,881.25	96,881.25	113,762.50
08/01/2028	-	-	15,661.25	15,661.25	-
02/01/2029	85,000.00	3.100%	15,661.25	100,661.25	116,322.50
08/01/2029	-	-	14,343.75	14,343.75	-
02/01/2030	90,000.00	3.200%	14,343.75	104,343.75	118,687.50
08/01/2030	-	-	12,903.75	12,903.75	-
02/01/2031	90,000.00	3.300%	12,903.75	102,903.75	115,807.50
08/01/2031	-	-	11,418.75	11,418.75	-
02/01/2032	95,000.00	3.400%	11,418.75	106,418.75	117,837.50
08/01/2032	-	-	9,803.75	9,803.75	-
02/01/2033	95,000.00	3.500%	9,803.75	104,803.75	114,607.50
08/01/2033	-	-	8,141.25	8,141.25	-
02/01/2034	100,000.00	3.600%	8,141.25	108,141.25	116,282.50
08/01/2034	-	-	6,341.25	6,341.25	-
02/01/2035	105,000.00	3.750%	6,341.25	111,341.25	117,682.50
08/01/2035	-	-	4,372.50	4,372.50	-
02/01/2036	110,000.00	3.850%	4,372.50	114,372.50	118,745.00
08/01/2036	-	-	2,255.00	2,255.00	-
02/01/2037	110,000.00	4.100%	2,255.00	112,255.00	114,510.00
<b>Total</b>	<b>\$960,000.00</b>	<b>-</b>	<b>\$223,846.01</b>	<b>\$1,183,846.01</b>	<b>-</b>

## Yield Statistics

Bond Year Dollars	\$6,112.33
Average Life	6.367 Years
Average Coupon	3.6622023%
Net Interest Cost (NIC)	3.8192618%
True Interest Cost (TIC)	3.8305626%
Bond Yield for Arbitrage Purposes	3.6494327%
All Inclusive Cost (AIC)	4.0615980%

## IRS Form 8038

Net Interest Cost	3.6622023%
Weighted Average Maturity	6.367 Years

# City of Waconia, Minnesota

\$960,000 GO Bonds, Series 2026A Water (444)

## Debt Service Schedule

Date	Principal	Coupon	Interest	Total P+I	Water Revenue 105% Overley
02/01/2027	-	-	19,601.01	19,601.01	20,581.06
02/01/2028	80,000.00	3.050%	33,762.50	113,762.50	119,450.63
02/01/2029	85,000.00	3.100%	31,322.50	116,322.50	122,138.63
02/01/2030	90,000.00	3.200%	28,687.50	118,687.50	124,621.88
02/01/2031	90,000.00	3.300%	25,807.50	115,807.50	121,597.88
02/01/2032	95,000.00	3.400%	22,837.50	117,837.50	123,729.38
02/01/2033	95,000.00	3.500%	19,607.50	114,607.50	120,337.88
02/01/2034	100,000.00	3.600%	16,282.50	116,282.50	122,096.63
02/01/2035	105,000.00	3.750%	12,682.50	117,682.50	123,566.63
02/01/2036	110,000.00	3.850%	8,745.00	118,745.00	124,682.25
02/01/2037	110,000.00	4.100%	4,510.00	114,510.00	120,235.50
<b>Total</b>	<b>\$960,000.00</b>	<b>-</b>	<b>\$223,846.01</b>	<b>\$1,183,846.01</b>	<b>\$1,243,038.31</b>

## Significant Dates

Dated	7/02/2026
First Coupon Date	2/01/2027

## Yield Statistics

Bond Year Dollars	\$6,112.33
Average Life	6.367 Years
Average Coupon	3.6622023%
Net Interest Cost (NIC)	3.8192618%
True Interest Cost (TIC)	3.8305626%
Bond Yield for Arbitrage Purposes	3.6494327%
All Inclusive Cost (AIC)	4.0615980%

## IRS Form 8038

Net Interest Cost	3.6622023%
Weighted Average Maturity	6.367 Years

# City of Waconia, Minnesota

\$255,000 GO Bonds, Series 2026A Storm Sewer (444)

## Debt Service Schedule

Date	Principal	Coupon	Interest	Total P+I	Fiscal Total
07/02/2026	-	-	-	-	-
02/01/2027	-	-	5,200.33	5,200.33	5,200.33
08/01/2027	-	-	4,478.75	4,478.75	-
02/01/2028	20,000.00	3.050%	4,478.75	24,478.75	28,957.50
08/01/2028	-	-	4,173.75	4,173.75	-
02/01/2029	25,000.00	3.100%	4,173.75	29,173.75	33,347.50
08/01/2029	-	-	3,786.25	3,786.25	-
02/01/2030	25,000.00	3.200%	3,786.25	28,786.25	32,572.50
08/01/2030	-	-	3,386.25	3,386.25	-
02/01/2031	25,000.00	3.300%	3,386.25	28,386.25	31,772.50
08/01/2031	-	-	2,973.75	2,973.75	-
02/01/2032	25,000.00	3.400%	2,973.75	27,973.75	30,947.50
08/01/2032	-	-	2,548.75	2,548.75	-
02/01/2033	25,000.00	3.500%	2,548.75	27,548.75	30,097.50
08/01/2033	-	-	2,111.25	2,111.25	-
02/01/2034	25,000.00	3.600%	2,111.25	27,111.25	29,222.50
08/01/2034	-	-	1,661.25	1,661.25	-
02/01/2035	25,000.00	3.750%	1,661.25	26,661.25	28,322.50
08/01/2035	-	-	1,192.50	1,192.50	-
02/01/2036	30,000.00	3.850%	1,192.50	31,192.50	32,385.00
08/01/2036	-	-	615.00	615.00	-
02/01/2037	30,000.00	4.100%	615.00	30,615.00	31,230.00
<b>Total</b>	<b>\$255,000.00</b>	<b>-</b>	<b>\$59,055.33</b>	<b>\$314,055.33</b>	<b>-</b>

## Yield Statistics

Bond Year Dollars	\$1,613.04
Average Life	6.326 Years
Average Coupon	3.6611162%
Net Interest Cost (NIC)	3.8192026%
True Interest Cost (TIC)	3.8301288%
Bond Yield for Arbitrage Purposes	3.6494327%
All Inclusive Cost (AIC)	4.0625656%

## IRS Form 8038

Net Interest Cost	3.6611162%
Weighted Average Maturity	6.326 Years

# City of Waconia, Minnesota

\$255,000 GO Bonds, Series 2026A Storm Sewer (444)

## Debt Service Schedule

Date	Principal	Coupon	Interest	Total P+I	Storm Sewer Revenue 105% Overlevy
02/01/2027	-	-	5,200.33	5,200.33	5,460.35
02/01/2028	20,000.00	3.050%	8,957.50	28,957.50	30,405.38
02/01/2029	25,000.00	3.100%	8,347.50	33,347.50	35,014.88
02/01/2030	25,000.00	3.200%	7,572.50	32,572.50	34,201.13
02/01/2031	25,000.00	3.300%	6,772.50	31,772.50	33,361.13
02/01/2032	25,000.00	3.400%	5,947.50	30,947.50	32,494.88
02/01/2033	25,000.00	3.500%	5,097.50	30,097.50	31,602.38
02/01/2034	25,000.00	3.600%	4,222.50	29,222.50	30,683.63
02/01/2035	25,000.00	3.750%	3,322.50	28,322.50	29,738.63
02/01/2036	30,000.00	3.850%	2,385.00	32,385.00	34,004.25
02/01/2037	30,000.00	4.100%	1,230.00	31,230.00	32,791.50
<b>Total</b>	<b>\$255,000.00</b>	<b>-</b>	<b>\$59,055.33</b>	<b>\$314,055.33</b>	<b>\$329,758.10</b>

## Significant Dates

Dated	7/02/2026
First Coupon Date	2/01/2027

## Yield Statistics

Bond Year Dollars	\$1,613.04
Average Life	6.326 Years
Average Coupon	3.6611162%
Net Interest Cost (NIC)	3.8192026%
True Interest Cost (TIC)	3.8301288%
Bond Yield for Arbitrage Purposes	3.6494327%
All Inclusive Cost (AIC)	4.0625656%

## IRS Form 8038

Net Interest Cost	3.6611162%
Weighted Average Maturity	6.326 Years

# City of Waconia, Minnesota

\$3,470,000 GO Bonds, Series 2026A Sanitary Sewer (115)

## Debt Service Schedule

Date	Principal	Coupon	Interest	Total P+I	Fiscal Total
07/02/2026	-	-	-	-	-
02/01/2027	-	-	70,837.94	70,837.94	70,837.94
08/01/2027	-	-	61,008.75	61,008.75	-
02/01/2028	300,000.00	3.050%	61,008.75	361,008.75	422,017.50
08/01/2028	-	-	56,433.75	56,433.75	-
02/01/2029	310,000.00	3.100%	56,433.75	366,433.75	422,867.50
08/01/2029	-	-	51,628.75	51,628.75	-
02/01/2030	315,000.00	3.200%	51,628.75	366,628.75	418,257.50
08/01/2030	-	-	46,588.75	46,588.75	-
02/01/2031	325,000.00	3.300%	46,588.75	371,588.75	418,177.50
08/01/2031	-	-	41,226.25	41,226.25	-
02/01/2032	340,000.00	3.400%	41,226.25	381,226.25	422,452.50
08/01/2032	-	-	35,446.25	35,446.25	-
02/01/2033	350,000.00	3.500%	35,446.25	385,446.25	420,892.50
08/01/2033	-	-	29,321.25	29,321.25	-
02/01/2034	360,000.00	3.600%	29,321.25	389,321.25	418,642.50
08/01/2034	-	-	22,841.25	22,841.25	-
02/01/2035	375,000.00	3.750%	22,841.25	397,841.25	420,682.50
08/01/2035	-	-	15,810.00	15,810.00	-
02/01/2036	390,000.00	3.850%	15,810.00	405,810.00	421,620.00
08/01/2036	-	-	8,302.50	8,302.50	-
02/01/2037	405,000.00	4.100%	8,302.50	413,302.50	421,605.00
<b>Total</b>	<b>\$3,470,000.00</b>	<b>-</b>	<b>\$808,052.94</b>	<b>\$4,278,052.94</b>	<b>-</b>

## Yield Statistics

Bond Year Dollars	\$22,059.53
Average Life	6.357 Years
Average Coupon	3.6630564%
Net Interest Cost (NIC)	3.8203580%
True Interest Cost (TIC)	3.8316200%
Bond Yield for Arbitrage Purposes	3.6494327%
All Inclusive Cost (AIC)	4.0630319%

## IRS Form 8038

Net Interest Cost	3.6630564%
Weighted Average Maturity	6.357 Years

# City of Waconia, Minnesota

\$3,470,000 GO Bonds, Series 2026A Sanitary Sewer (115)

## Debt Service Schedule

Date	Principal	Coupon	Interest	Total P+I	105% Overlevy
02/01/2027	-	-	70,837.94	70,837.94	74,379.84
02/01/2028	300,000.00	3.050%	122,017.50	422,017.50	443,118.38
02/01/2029	310,000.00	3.100%	112,867.50	422,867.50	444,010.88
02/01/2030	315,000.00	3.200%	103,257.50	418,257.50	439,170.38
02/01/2031	325,000.00	3.300%	93,177.50	418,177.50	439,086.38
02/01/2032	340,000.00	3.400%	82,452.50	422,452.50	443,575.13
02/01/2033	350,000.00	3.500%	70,892.50	420,892.50	441,937.13
02/01/2034	360,000.00	3.600%	58,642.50	418,642.50	439,574.63
02/01/2035	375,000.00	3.750%	45,682.50	420,682.50	441,716.63
02/01/2036	390,000.00	3.850%	31,620.00	421,620.00	442,701.00
02/01/2037	405,000.00	4.100%	16,605.00	421,605.00	442,685.25
<b>Total</b>	<b>\$3,470,000.00</b>	<b>-</b>	<b>\$808,052.94</b>	<b>\$4,278,052.94</b>	<b>\$4,491,955.59</b>

## Significant Dates

Dated	7/02/2026
First Coupon Date	2/01/2027

## Yield Statistics

Bond Year Dollars	\$22,059.53
Average Life	6.357 Years
Average Coupon	3.6630564%
Net Interest Cost (NIC)	3.8203580%
True Interest Cost (TIC)	3.8316200%
Bond Yield for Arbitrage Purposes	3.6494327%
All Inclusive Cost (AIC)	4.0630319%

## IRS Form 8038

Net Interest Cost	3.6630564%
Weighted Average Maturity	6.357 Years

# City of Waconia, Minnesota

\$1,032,456 General Obligation Bonds, Series 2026A Assessments

1.0% over TIC - Equal P&I

## Assessments

Date	Principal	Coupon	Interest	Total P+I
12/31/2027	82,661.42	4.850%	50,074.12	132,735.54
12/31/2028	86,670.50	4.850%	46,065.04	132,735.54
12/31/2029	90,874.02	4.850%	41,861.52	132,735.54
12/31/2030	95,281.41	4.850%	37,454.12	132,735.53
12/31/2031	99,902.55	4.850%	32,832.98	132,735.53
12/31/2032	104,747.83	4.850%	27,987.70	132,735.53
12/31/2033	109,828.10	4.850%	22,907.44	132,735.54
12/31/2034	115,154.76	4.850%	17,580.78	132,735.54
12/31/2035	120,739.77	4.850%	11,995.76	132,735.53
12/31/2036	126,595.64	4.850%	6,139.88	132,735.52
<b>Total</b>	<b>\$1,032,456.00</b>	<b>-</b>	<b>\$294,899.34</b>	<b>\$1,327,355.34</b>

## Significant Dates

Filing Date	1/01/2027
First Payment Date	12/31/2027

# 30 YEAR TREND IN MUNICIPAL BOND INDICES

## Weekly Rates March, 1996 - March, 2026

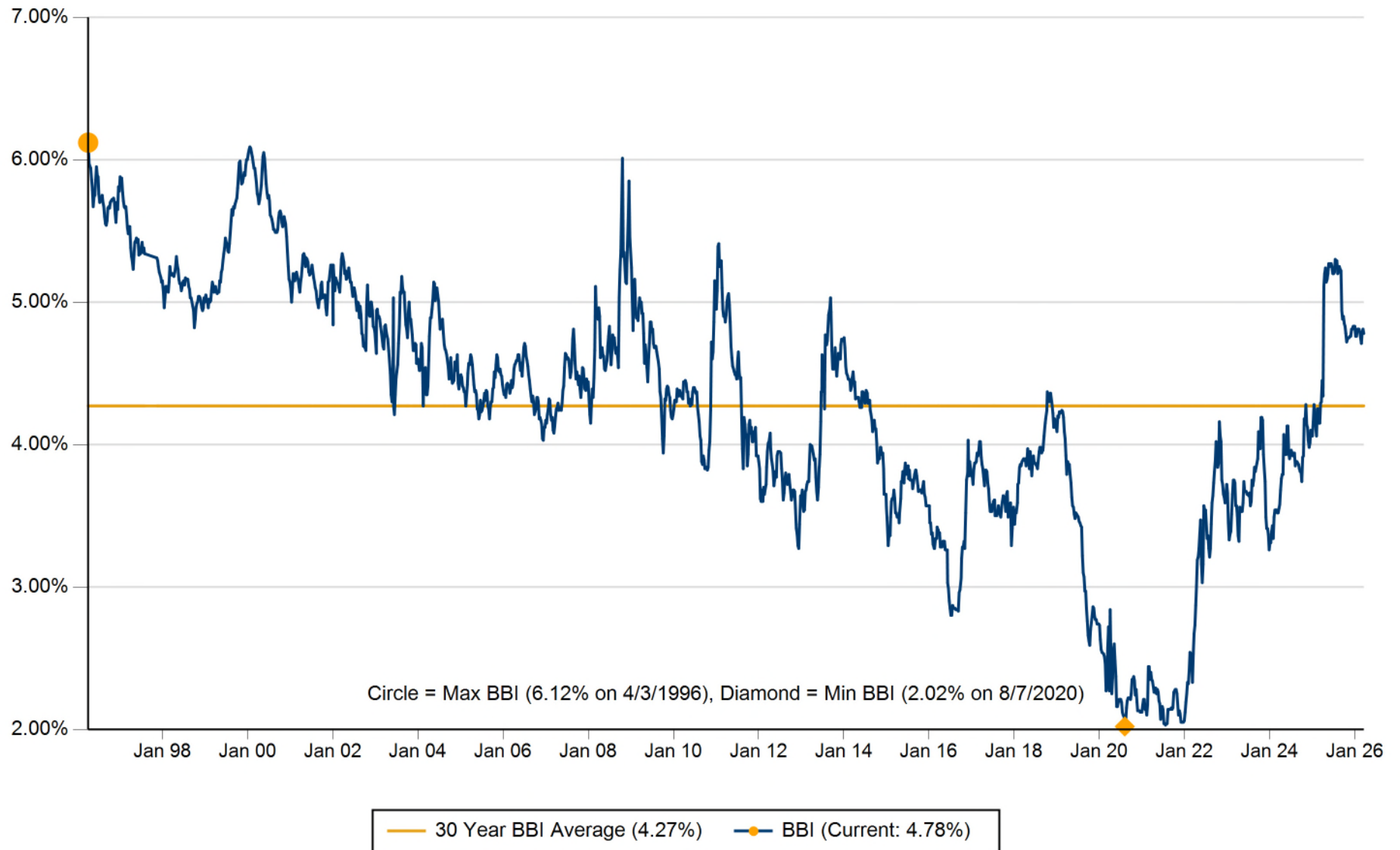

The Bond Buyer "20 Bond Index" (BBI) shows average yields on a group of municipal bonds that mature in 20 years and have an average rating equivalent to Moody's Aa2 and S&P's AA.

Source: The Bond Buyer



EXTRACT OF MINUTES OF A MEETING OF THE  
CITY COUNCIL OF THE CITY OF WACONIA, MINNESOTA

HELD: APRIL 6, 2026

Pursuant to due call and notice thereof, a regular or special meeting of the City Council of the City of Waconia, Carver County, Minnesota, was duly held at City Hall on April 6, 2026, at 6:00 P.M., for the purpose, in part, of providing for the issuance and sale of \$3,265,000 General Obligation Temporary Street Reconstruction Plan Bonds, Series 2026B.

The following members were present: LITFIN, GRENGS, COLEMAN, GLEASON, AND SIDDON

and the following were absent: NONE

Member \_\_\_\_\_ introduced the following resolution and moved its adoption:

RESOLUTION NO. 2026-104

RESOLUTION PROVIDING FOR THE ISSUANCE AND SALE OF  
\$3,265,000 GENERAL OBLIGATION TEMPORARY STREET  
RECONSTRUCTION PLAN BONDS, SERIES 2026B

A. WHEREAS, the City Council (the "Council") of the City of Waconia, Minnesota (the "City") has heretofore determined that it is necessary and expedient to issue the City's \$3,265,000 General Obligation Temporary Street Reconstruction Plan Bonds, Series 2026B (the "Bonds"), to finance the construction of the City's 2026 Highway 5 Phase 2 Street Reconstruction Project in anticipation of state aid and grant receipts; and

B. WHEREAS, the City has retained Ehlers & Associates, Inc., in Minneapolis, Minnesota ("Ehlers"), as its independent municipal advisor for the Bonds in accordance with Minnesota Statutes, Section 475.60, Subdivision 2(9).

NOW, THEREFORE, BE IT RESOLVED by the City of Waconia, Minnesota, as follows:

1. Authorization. The Council hereby authorizes Ehlers to assist the City for the sale of the Bonds.
2. Meeting; Proposal Opening. The Council shall meet at 6:00 P.M. on June 15, 2026, for the purpose of considering proposals for and awarding the sale of the Bonds.
3. Official Statement. In connection with said sale, the officers or employees of the City are hereby authorized to cooperate with Ehlers and participate in the preparation of an official statement for the Bonds and to execute and deliver it on behalf of the City upon its completion.

The motion for the adoption of the foregoing resolution was duly seconded by Council Member \_\_\_\_\_ and, after full discussion thereof and upon a vote being

taken thereon, the following Council Members voted in favor thereof: LITFIN, GRENGS, COLEMAN, GLEASON, AND SIDDONS

and the following voted against the same: NONE

Whereupon said resolution was declared duly passed and adopted.

STATE OF MINNESOTA  
CARVER COUNTY  
CITY OF WACONIA

I, the undersigned, being the duly qualified and acting City Administrator of the City of Waconia, Minnesota, DO HEREBY CERTIFY that I have compared the attached and foregoing extract of minutes with the original thereof on file in my office, and that the same is a full, true and complete transcript of the minutes of a meeting of the City Council, duly called and held on the date therein indicated, insofar as the minutes relate to providing for the issuance and sale of \$3,265,000 General Obligation Temporary Street Reconstruction Plan Bonds, Series 2026B.

WITNESS my hand on April 6, 2026.

---

Shane Fineran, City Administrator

April 6, 2026

PRE-SALE REPORT FOR

## City of Waconia, Minnesota

**\$3,265,000 General Obligation Temporary Street  
Reconstruction Plan Bonds, Series 2026B**



---

**Prepared by:**

Ehlers  
3001 Broadway Street, Suite 320  
Minneapolis, MN 55413

**Advisors:**

Todd Hagen, Senior Municipal Advisor  
Bruce Kimmel, Senior Municipal Advisor  
Keith Dahl, Senior Municipal Advisor

---

**BUILDING COMMUNITIES. IT'S WHAT WE DO.**

# EXECUTIVE SUMMARY OF PROPOSED DEBT

## Proposed Issue:

\$3,265,000 General Obligation Temporary Street Reconstruction Plan Bonds, Series 2026B

The City has directed Ehlers to assist in a financing method that combines three issuance authorities into one bond, does not require voter approval, and would allow for payments over 10 years.

## Purpose:

The proposed issue includes fixed rate/tax-exempt temporary financing for the construction of the City's 2026 Highway 5 Phase 2 Street Reconstruction Project in anticipation of State aid and grant receipts.

Debt service will be paid from capitalized interest, long-term bonds or additional temporary bonds, and ad valorem property taxes. Any long-term bonds are expected to be paid from property taxes.

## Authority:

The Bonds are being issued pursuant to Minnesota Statutes, Chapter 475 (street reconstruction plan and general bonding authority).

The Bonds requires a public hearing and a 30-day reverse referendum period to allow for the issuance of bonds and to approve the street reconstruction plan. The public hearing will be held on May 4, 2026. The reverse referendum period ends on June 3, 2026.

The Bonds count against the Net Debt Limit of 3% of the estimated market value of taxable property in the City. The Bonds do not exceed the City's debt limit.

The Bonds will be general obligations of the City for which its full faith, credit and taxing powers are pledged.

## Term/Call Feature:

The Bonds are being issued for a term of 3 years. Principal on the Bonds will be due on February 1, 2029. Interest is payable every six months beginning February 1, 2027. The interest will be paid from bond proceeds deposited in the capitalized interest fund.

The Bonds will be subject to prepayment at the discretion of the City on August 1, 2027 or any date thereafter.

## Not Bank Qualified:

Because the City is expecting to issue more than \$10,000,000 in tax exempt debt during the calendar year, the City will not be able to designate the Bonds as "bank qualified" obligations.

Bank qualified status broadens the market for the Bonds, which can result in lower interest rates.

### **Rating:**

The City's most recent bond issues were rated by S&P Global Ratings. The current rating on those bonds is "AA+". The City will request a new rating for the Bonds.

If the winning bidder on the Bonds elects to purchase bond insurance, the rating for the issue may be higher than the City's bond rating if the bond rating of the insurer is higher than that of the City.

### **Basis for Recommendation:**

Based on our knowledge of the City's situation, their objectives communicated to us, our advisory relationship as well as characteristics of various financing options, we are recommending the issuance of general obligation temporary street reconstruction plan bonds with a full competitive sale as a suitable financing option for the following reasons:

- General obligation bonds provide a straight-forward approach to financing projects identified by the City.
- We expect that the size and term of the issue, with bank qualification and a high bond rating, will attract several quality bids based upon similar recent sales in Minnesota.
- The City does not expect to have surplus resources adequate to prepay the debt prior to the scheduled maturities.
- This is generally the most overall cost-effective option.

Because of its larger size, we are recommending against offering the Bonds to a limited number of local and regional banks and selling this issue rated through a full competitive process to the public market using an official statement. Also, there are no special circumstances that would require a negotiated sale. This method of sale complies with City policy as well as best practices endorsed by the Government Finance Officers Association (GFOA).

### **Method of Sale/Placement:**

We will solicit competitive bids for the sale of the Bonds to underwriters and banks as the size, structure and term will likely result in the maximum number of bids at the lowest interest rates and is a desirable credit for municipal bond investors.

We will include an allowance for discount bidding in the terms of the issue. The discount is treated as an interest item and provides the underwriter with all or a portion of their compensation in the transaction.

If the Bonds are purchased at a price greater than the minimum bid amount (maximum discount), the unused allowance may be used to reduce your borrowing amount.

### **Premium Pricing:**

In some cases, investors in municipal bonds prefer "premium" pricing structures. A premium is achieved when the coupon for any maturity (the interest rate paid by the issuer) exceeds

the yield to the investor, resulting in a price paid that is greater than the face value of the bonds. The sum of the amounts paid more than face value is considered “reoffering premium.” The underwriter of the bonds will retain a portion of this reoffering premium as their compensation (or “discount”) but will pay the remainder of the premium to the City.

For this issue of Bonds, we have been directed to use the net premium to reduce the size of the issue rather than increase the net proceeds for the project; but that could change on the day of sale. The resulting adjustments may slightly change the true interest cost of the issue, either up or down.

### **Review of Existing Debt:**

We have reviewed all outstanding indebtedness for the City and find that there are no refunding opportunities at this time.

We will continue to monitor the market and the call dates for the City’s outstanding debt and will alert you to any future refunding opportunities.

### **Continuing Disclosure:**

Because the City has more than \$10,000,000 in outstanding debt subject to a continuing disclosure undertaking (including this issue) and this issue does not meet an available exemption from continuing disclosure, the City will be agreeing to provide certain updated Annual Financial Information and its Audited Financial Statements annually, as well as providing notices of the occurrence of certain reportable events to the Municipal Securities Rulemaking Board (the “MSRB”), as required by rules of the Securities and Exchange Commission (SEC).

The City is already obligated to provide such reports for its existing bonds and has contracted with Ehlers to prepare and file the reports.

### **Arbitrage Monitoring:**

The City must ensure compliance with certain sections of the Internal Revenue Code and Treasury Regulations (“Arbitrage Rules”) throughout the life of the issue to maintain the tax-exempt status of the Bonds. These Arbitrage Rules apply to amounts held in construction, escrow, reserve, debt service account(s), etc., along with related investment income on each fund/account.

IRS audits will verify compliance with rebate, yield restriction and records retention requirements within the Arbitrage Rules. The City’s specific arbitrage responsibilities will be detailed in the Nonarbitrage Certificate prepared by your bond attorney and provided at closing.

**Two-Year (24-month) Spending Exception** – The City expects to meet the two-year expenditure exception on the Bond proceeds. If the City fails to meet the expenditure exceptions, it will be required to pay rebate.

We recommend that the City review its specific responsibilities related to the Bonds with an arbitrage expert to help monitor the exception used above.

An Ehlers arbitrage expert will contact the City within 30 days after the sale date to review the City's specific responsibilities for the Bonds. The City is currently receiving arbitrage services from Ehlers in relation to the Bonds.

### **Investment of Bond Proceeds:**

Ehlers can assist the City in developing a strategy to invest your Bond proceeds until the funds are needed to pay project costs.

### **Risk Factors:**

**GO Pledge:** Because the Bonds will be general obligations of the City for which its full faith, credit and taxing powers are pledged, if the annual tax levy collected is not sufficient to pay the debt service payments, other City funds will need to be used.

### **Other Service Providers:**

This debt issuance will require the engagement of other public finance service providers. This section identifies those other service providers, so Ehlers can coordinate their engagement on your behalf. Where you have previously used a particular firm to provide a service, we have assumed that you will continue that relationship. For services you have not previously required, we have identified a service provider. Fees charged by these service providers will be paid from proceeds of the obligation, unless you notify us that you wish to pay them from other sources. Our pre-sale bond sizing includes a good faith estimate of these fees, but the final fees may vary. If you have any questions pertaining to the identified service providers or their role, or if you would like to use a different service provider for any of the listed services, please contact us.

**Bond Counsel:** Taft Stettinius & Hollister

**Paying Agent:** Bond Trust Services

**Rating Agency:** S&P Global Ratings

### **Summary:**

The decisions to be made by the City Council are as follows:

- Accept or modify the finance assumptions described in this report.
- Adopt the resolution attached to this report.

This pre-sale report summarizes our understanding of the City's objectives for the structure and terms of this financing as of this date. As additional facts become known or capital markets conditions change, we may need to modify the structure and/or terms of this financing to achieve results consistent with the City's objectives.

## PROPOSED DEBT ISSUANCE SCHEDULE

Pre-Sale Review by City Council:	April 6, 2026
Public Hearing on Street Reconstruction Plan (SRP):	May 4, 2026
Due Diligence Call to review Official Statement/Conference with Rating Agency:	Week of June 1, 2026
Reverse Referendum Period Ends on SRP:	June 3, 2026
Print Official Statement:	June 4, 2026
City Council Meeting to Award Sale of the Bonds:	June 15, 2026
Estimated Closing Date:	July 2, 2026

### Attachments

Estimated Sources and Uses of Funds

Estimated Proposed Debt Service Schedule

Bond Buyer Index

Resolutions Authorizing Ehlers to Proceed with Bond Sale, and Calling Public Hearing on SRP (provided separately)

## EHLERS' CONTACTS

Todd Hagen, Senior Municipal Advisor	(651) 697-8508
Bruce Kimmel, Senior Municipal Advisor	(651) 697-8572
Keith Dahl, Senior Municipal Advisor	(651) 697-8595
Silvia Johnson, Lead Public Finance Analyst	(651) 697-8580
Alicia Gage, Senior Financial Analyst	(651) 697-8551

# City of Waconia, Minnesota

\$3,280,000 GO Temporary Street Reconstruction Plan Bonds, Series 2026B  
Assumes Current Market Non-BQ "AA+" Rates plus 50bps

## Sources & Uses

Dated 07/02/2026 | Delivered 07/02/2026

### Sources Of Funds

Par Amount of Bonds	\$3,280,000.00
<b>Total Sources</b>	<b>\$3,280,000.00</b>

### Uses Of Funds

Total Underwriter's Discount (0.600%)	19,680.00
Costs of Issuance	48,000.00
Deposit to Capitalized Interest (CIF) Fund	211,550.89
Deposit to Project Construction Fund	3,000,000.00
Rounding Amount	769.11
<b>Total Uses</b>	<b>\$3,280,000.00</b>

# City of Waconia, Minnesota

\$3,280,000 GO Temporary Street Reconstruction Plan Bonds, Series 2026B

Assumes Current Market Non-BQ "AA+" Rates plus 50bps

## Debt Service Schedule

Date	Principal	Coupon	Interest	Total P+I	Fiscal Total
07/02/2026	-	-	-	-	-
02/01/2027	-	-	59,030.89	59,030.89	59,030.89
08/01/2027	-	-	50,840.00	50,840.00	-
02/01/2028	-	-	50,840.00	50,840.00	101,680.00
08/01/2028	-	-	50,840.00	50,840.00	-
02/01/2029	3,280,000.00	3.100%	50,840.00	3,330,840.00	3,381,680.00
<b>Total</b>	<b>\$3,280,000.00</b>	<b>-</b>	<b>\$262,390.89</b>	<b>\$3,542,390.89</b>	<b>-</b>

## Yield Statistics

Bond Year Dollars	\$8,464.22
Average Life	2.581 Years
Average Coupon	3.1000000%
Net Interest Cost (NIC)	3.3325081%
True Interest Cost (TIC)	3.3436555%
Bond Yield for Arbitrage Purposes	3.0991075%
All Inclusive Cost (AIC)	3.9477360%

## IRS Form 8038

Net Interest Cost	3.1000000%
Weighted Average Maturity	2.581 Years

# City of Waconia, Minnesota

\$3,280,000 GO Temporary Street Reconstruction Plan Bonds, Series 2026B  
 Assumes Current Market Non-BQ "AA+" Rates plus 50bps

## Net Debt Service Schedule

Date	Principal	Coupon	Interest	Total P+I	CIF	Net New D/S	Fiscal Total
07/02/2026	-	-	-	-	-	-	-
02/01/2027	-	-	59,030.89	59,030.89	(59,030.89)	-	-
08/01/2027	-	-	50,840.00	50,840.00	(50,840.00)	-	-
02/01/2028	-	-	50,840.00	50,840.00	(50,840.00)	-	-
08/01/2028	-	-	50,840.00	50,840.00	(50,840.00)	-	-
02/01/2029	3,280,000.00	3.100%	50,840.00	3,330,840.00	-	3,330,840.00	3,330,840.00
<b>Total</b>	<b>\$3,280,000.00</b>	<b>-</b>	<b>\$262,390.89</b>	<b>\$3,542,390.89</b>	<b>(211,550.89)</b>	<b>\$3,330,840.00</b>	<b>-</b>

## Significant Dates

Dated 7/02/2026  
 First available call date

# 30 YEAR TREND IN MUNICIPAL BOND INDICES

## Weekly Rates March, 1996 - March, 2026

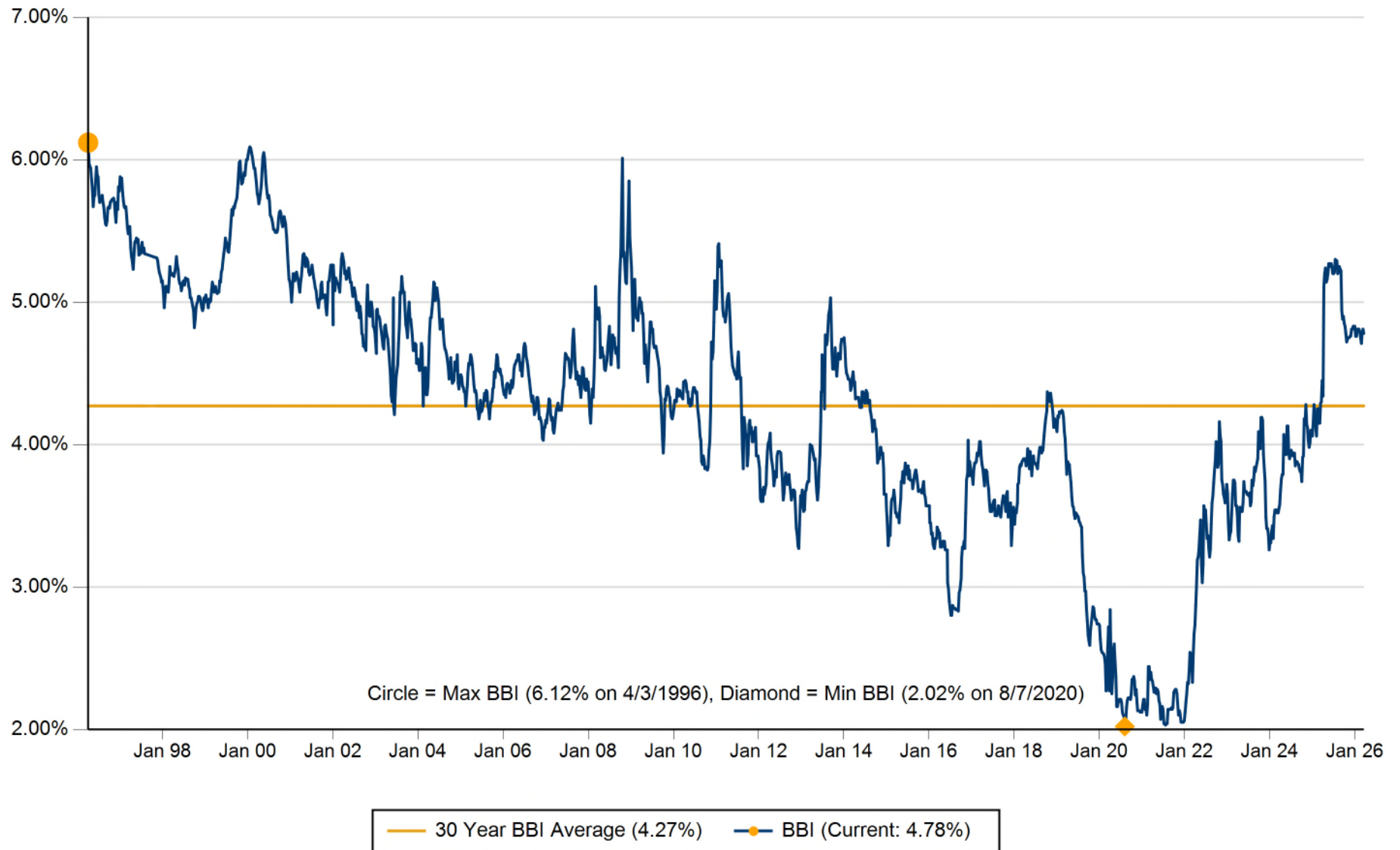

The Bond Buyer "20 Bond Index" (BBI) shows average yields on a group of municipal bonds that mature in 20 years and have an average rating equivalent to Moody's Aa2 and S&P's AA.

Source: The Bond Buyer



EXTRACT OF MINUTES OF A MEETING OF THE  
CITY COUNCIL OF THE CITY OF WACONIA, MINNESOTA

HELD: APRIL 6, 2026

Pursuant to due call and notice thereof, a regular or special meeting of the City Council of the City of Waconia, Carver County, Minnesota, was duly held at City Hall on April 6, 2026, at 6:00 P.M., for the purpose, in part, of calling for a public hearing on a street reconstruction plan and the intent to issue general obligation street reconstruction bonds.

The following members were present: LITFIN, GRENGS, COLEMAN, GLEASON,  
AND SIDDON

and the following were absent: NONE

Member \_\_\_\_\_ introduced the following resolution and moved its adoption:

RESOLUTION NO. 2026-105

RESOLUTION CALLING A PUBLIC HEARING ON THE PROPOSAL TO  
ADOPT A STREET RECONSTRUCTION PLAN AND THE INTENT TO  
ISSUE GENERAL OBLIGATION STREET RECONSTRUCTION BONDS

WHEREAS, the City Council (the "Council") of the City of Waconia, Minnesota (the "City"), proposes that it is the best interest of the City to issue and sell general obligation street reconstruction bonds pursuant to Minnesota Statutes, Section 475.58, subdivision 3b, as amended (the "Act"), to finance the cost of street reconstruction projects, as described in the proposed street reconstruction plan described below, a copy of which is on file in the City Administrator's office; and

WHEREAS, pursuant to the Act, the City is authorized to issue and sell general obligation street reconstruction bonds to finance street reconstruction under the circumstances and within the limitations set forth in the Act; and the Act provides that street reconstruction projects may be financed with general obligation street reconstruction bonds, following adoption of a street reconstruction plan, after a public hearing on the street reconstruction plan and on the issuance of general obligation street reconstruction bonds and other proceedings conducted in accordance with the requirements of the Act; and

WHEREAS, pursuant to the Act, the City has undertaken to prepare a five year street reconstruction plan for calendar years 2026 through 2030, which describes the streets to be reconstructed, the estimated costs and any planned reconstruction of other streets in the City, including the issuance of general obligation street reconstruction bonds under the Act (the "Plan"), to determine the funding strategy for street reconstruction projects.

NOW, THEREFORE, BE IT RESOLVED by the City Council of the City of Waconia, Minnesota, as follows:

1. Public Hearing. The Council hereby determines to call for and to hold a public hearing on the Plan and the issuance of general obligation street reconstruction bonds thereunder at a meeting of the Council to be held on May 4, 2026, the public hearing shall commence at 6:00 P.M.

2. Publication. The staff of the City is hereby authorized and directed to cause the Notice of Public Hearing which is attached to this Resolution to be published in the City's official newspaper not less than 10 days nor more than 28 days prior to the scheduled public hearing date.

The motion for the adoption of the foregoing resolution was duly seconded by member \_\_\_\_\_ and, after a full discussion thereof and upon a vote being taken thereon, the following voted in favor thereof:

and the following voted against the same: LITFIN, GRENGS, COLEMAN, GLEASON, AND SIDDON

Whereupon the resolution was declared duly passed and adopted.

STATE OF MINNESOTA  
CARVER COUNTY  
CITY OF WACONIA

I, the undersigned, being duly qualified and acting City Administrator of the City of Waconia, Minnesota, DO HEREBY CERTIFY that I have compared the attached and foregoing extract of minutes with the original thereof on file in my office, and that the same is a full, true and complete transcript of the minutes of a meeting of the City Council, duly called and held on the date therein indicated, insofar as such minutes relate to calling a public hearing on a street reconstruction plan and the issuance of general obligation street reconstruction bonds.

WITNESS my hand April 6, 2026.

---

Shane Fineran, City Administrator

EXHIBIT A

CITY OF WACONIA, MINNESOTA

NOTICE OF PUBLIC HEARING ON THE PROPOSAL TO ADOPT A  
STREET RECONSTRUCTION PLAN AND THE INTENT TO ISSUE  
GENERAL OBLIGATION STREET RECONSTRUCTION BONDS

NOTICE IS HEREBY GIVEN that the City Council (the "Council") of the City of Waconia, Minnesota (the "City"), will meet on May 4, 2026, at 6:00 P.M., at the City Hall, 201 South Vine Street, Waconia, Minnesota, for the purpose of conducting a public hearing on (a) the proposal to adopt a five year street reconstruction plan and (b) the intent to issue not to exceed \$3,300,000 general obligation street reconstruction bonds under its street reconstruction plan for street reconstruction improvements described in the street reconstruction plan.

If a petition requesting a vote on the issuance of the general obligation street reconstruction bonds is signed by voters equal to five percent of the votes cast in the last municipal general election and is filed with the City Administrator within 30 days after the public hearing, the City may issue the general obligation street reconstruction bonds only after obtaining the approval of a majority of the voters voting on the question of the issuance of the general obligation street reconstruction bonds.

All interested persons may appear at the May 4, 2026 public hearing and present their views orally; or if in writing contact the City Administrator's office at 201 South Vine Street, Waconia, MN 55387 or 952-442-2184.

BY ORDER OF THE CITY COUNCIL

/s/ Shane Fineran, City Administrator

**"Exhibit A"**

**Total 2026 Infrastructure Project Cost & Financing Breakdown**

<u>Number</u>	<u>Project</u>	<u>Project Cost</u>	<u>Financing</u>
1	Street Reconstruction - Portions of 1st/Olive/2nd Street - Street Portion	\$ 2,557,333	429 Special Assessment Bonds
1	Street Reconstruction - Portions of 1st/Olive/2nd Street - Sidewalk Portion	\$ 494,032	429 Special Assessment Bonds (developer contribution)
1	Street Reconstruction - Portions of 1st/Olive/2nd Street - Lighting Portion (Street & Park)	\$ 937,768	429 Special Assessment Bonds
1	Street Reconstruction - Portions of 1st/Olive/2nd Street - Parking Lot	\$ 308,050	429 Special Assessment Bonds
1	Street Reconstruction - Portions of 1st/Olive/2nd Street - Signage Portion/Electric for Trailer	\$ 62,000	429 Special Assessment Bonds
1	Street Reconstruction - Portions of 1st/Olive/2nd Street - Holiday Lighting	\$ 35,000	429 Special Assessment Bonds
1	Street Reconstruction - Portions of 1st/Olive/2nd Street - Water	\$ 938,660	Water Bonds - 444
1	Street Reconstruction - Portions of 1st/Olive/2nd Street - Sewer	\$ 395,225	Sewer Bonds - 115
1	Street Reconstruction - Portions of 1st/Olive/2nd Street - Storm Water	\$ 247,016	Storm Water Bonds - 444
2	Mill & Overlay Project - Landing	\$ 222,000	429 Special Assessment Bonds
3	Reitz Lake Lift Station Construction	\$ 3,000,000	Sewer Bonds - 115
4	Highway 5 Phase 2 - Temporary Bond for Easement Acquisition-Engineering Expense	\$ 3,000,000	Temporary Bond - 3 Year Principal Repayment
<b>Total 2026 Project Costs:</b>		<b>\$ 12,197,084</b>	

**429 Special Assessment Bonds**

<u>Number</u>	<u>Project</u>	<u>Project Cost</u>	<u>Financing</u>
1	Street Reconstruction - Portions of 1st/Olive/2nd Street - Street Portion	\$ 2,557,333	429 Special Assessment Bonds
1	Street Reconstruction - Portions of 1st/Olive/2nd Street - Sidewalk Portion	\$ 494,032	429 Special Assessment Bonds
1	Street Reconstruction - Portions of 1st/Olive/2nd Street - Lighting Portion (Street & Park)	\$ 937,768	429 Special Assessment Bonds
1	Street Reconstruction - Portions of 1st/Olive/2nd Street - Parking Lot	\$ 308,050	429 Special Assessment Bonds
1	Street Reconstruction - Portions of 1st/Olive/2nd Street - Holiday Lighting	\$ 35,000	429 Special Assessment Bonds
1	Street Reconstruction - Portions of 1st/Olive/2nd Street - Signage Portion/Electric for Trailer	\$ 62,000	429 Special Assessment Bonds
2	Mill & Overlay Project - Landing	\$ 222,000	429 Special Assessment Bonds
<b>Total 429 Special Assessment Bonds:</b>		<b>\$ 4,616,182.69</b>	

**Water Bonds**

<u>Number</u>	<u>Project</u>	<u>Project Cost</u>	<u>Financing</u>
1	Street Reconstruction - Portions of 1st/Olive/2nd Street - Water	\$ 938,660	Water Bonds - 444
<b>Total Water Bonds:</b>		<b>\$ 938,660</b>	

**Sewer Bonds**

<u>Number</u>	<u>Project</u>	<u>Project Cost</u>	<u>Financing</u>
1	Street Reconstruction - Portions of 1st/Olive/2nd Street - Sewer	\$ 395,225	Sewer Bonds - 115
3	Reitz Lake Lift Station Construction	\$ 3,000,000	Sewer Bonds - 115
<b>Total Sewer Bonds:</b>		<b>\$ 3,395,225</b>	

**Storm Water Bonds**

<u>Number</u>	<u>Project</u>	<u>Project Cost</u>	<u>Financing</u>
1	Street Reconstruction - Portions of 1st/Olive/2nd Street - Storm Water	\$ 247,016	Storm Water Bonds - 444
<b>Total Storm Water Bonds:</b>		<b>\$ 247,016</b>	

**Temporary Street Reconstruction Bond - 3 Years**

<u>Number</u>	<u>Project</u>	<u>Project Cost</u>	<u>Financing</u>
4	Highway 5 Phase 2 - Temporary Bond for Easement Acquisition-Engineering Expense	\$ 3,000,000	Temporary Bond - 3 Year Principal Repayment
<b>Total Storm Water Bonds:</b>		<b>\$ 3,000,000</b>	